

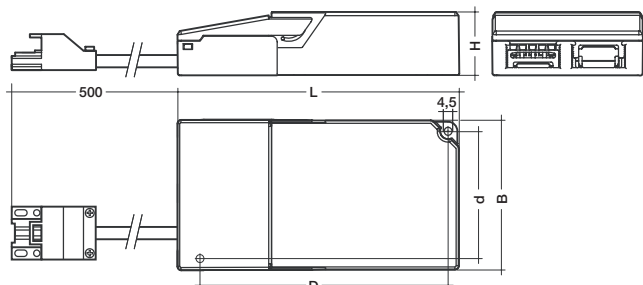

Digital electronic ballasts with lamp connection cable for remote mounted applications Metal halide lamps

powerCONTROL PCI 0035 / PCI 0070 / PCI 0150



The digital components in powerCONTROL control the power circuit and ignition. powerCONTROL is suitable for metal halide lamps. The basic circuit elements are patented. The ballasts were especially designed for mounted applications.

- operate quartz- and ceramic burner lamps
- flicker free light
- stable colour through constant light output
- lamp life increased up to **50 %**
- power consumption reduced by **10–20 %**
- lightweight
- no acoustic resonance
- switches off when the lamp is missing or faulty
- re-strike time reduced by up to **50 %**

- increased ignition energy thanks to pulse packages (*PulseControl* technology)
- electromagnetic interference during ignition reduced by up to **95 %**
- overtemperature cut off
- screw terminals up to 1.5 mm² for flexible wire, up to 2.5 mm² for solid wire
- mains-side through-wiring possible
- **halogen-free lamp cable with GST18 socket and interlock lug**
- can be used in movable luminaires with plugs (discharge voltage < 34 V after 1 s)
- one-piece housing in black polyamide IP20
- integrated terminal cover and cable clamp
- no tools required for installing the terminal cover and cable clamps

Type		PCI 0035 B521	PCI 0070 B521	PCI 0150 B521
article number		86458404	86458405	86458406
wattage	W	39	72	147
total wattage at ta = 25 °C	W	44	79	159
mains voltage	V	220–240	220–240	220–240
AC voltage range	V	198–254	198–254	198–254
DC voltage range	V	153–320	153–320	153–320
current	A	0.20	0.35	0.70
mains frequency	Hz	0/50/60	0/50/60	0/50/60
power factor	λ	0.97	0.97	0.97
operating frequency	Hz	145	145	145
max. ignition voltage	kVp	5	5	5
length of the lamp cable	m	0.5	0.5	0.5
connection type (lamp cable)		GST	GST	GST
max. cable length to lamp	m/pF	3/240	3/240	3/240
max. ambient temperature ta	°C	50	50	45
min. ambient temperature ta	°C	-25	-25	-25
permissible housing temperature tc	°C	65	75	75
diameter of ceiling opening	mm	> 85	> 85	> 86
fixing centres length (D)	mm	127.6	127.6	187.6
fixing centres width (d)	mm	68.6	68.6	68.6
length x width x height	mm	150 x 79.5 x 34	150 x 79.5 x 34	210 x 79.5 x 35
weight	g	290	300	420

Installation instructions

Wiring type and cross section

Stranded wire with end ferrule with a cross section up to 1.5 mm² or solid wire up to 2.5 mm² may be used for wiring.

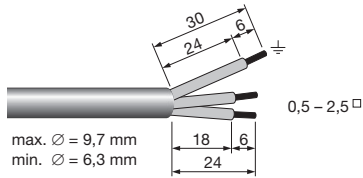

Lamp cable connector

Black GST-18 socket with interlock lug

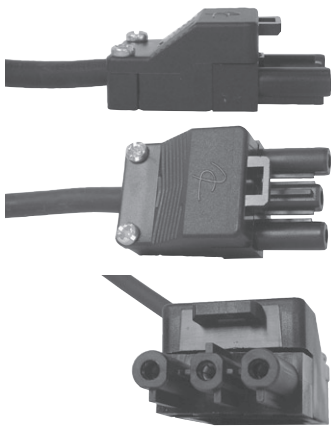

Terminals

Screw type M3
Torque 0.5 Nm

Packing quantities

single pack
box of 12
24 boxes/pallet
288 pieces/pallet

Harmonic distortion in the mains supply

Ballast Type	THD	3	5	7	9	11
PCI 0035	7.2	3.9	3.8	2.4	3.0	1.7
PCI 0070	6.6	3.7	3.3	2.2	2.6	1.7
PCI 0150	7.5	3.9	4.4	1.7	2.0	0.7

Loading of automatic circuit breakers

Automatic circuit

breaker type	C10	C13	C16	C20	B10	B13	B16	B20
Installation Ø	1.5 mm ²	1.5 mm ²	1.5 mm ²	2.5 mm ²	1.5 mm ²	1.5 mm ²	1.5 mm ²	2.5 mm ²
PCI 0035	30	40	50	60	15	20	25	30
PCI 0070	14	25	36	42	8	14	18	18
PCI 0150	7	14	20	20	4	6	7	7

Radio interference

- Do not cross mains and lamp cables.
- Do not lay mains cables together with lamp cables (ideally they should be 5–10 cm apart).
- Do not lead mains cables too closely along the electronic ballast.
- Twist lamp cables.
- Increase the distance between lamp cables and earthed metal surfaces.
- Keep the mains cable short.
- Parallel runs (x) of mains and lamp cables must be kept as short as possible.

Important advise

When a lamp is changed (at the end of its life), if a lamp is missing or after overtemperature shutdown the mains voltage of the ECG must be disconnected.

Warning – starting voltage up to max. 5 kV!

Not suitable for use with lamps with integral ignitors.

Note on wiring

The length of the lamp wires is limited by the value of cable capacitance. The maximum of 240 pF would enable connection of approximately 3 metres of lamp wire.

In class 1 luminaires it is necessary to earth the ballast and the luminaire.

Fixing conditions

Dry, acidfree, oilfree, fatfree. The maximum ambient temperature should not be exceeded. Is not suitable for fixing in corner.

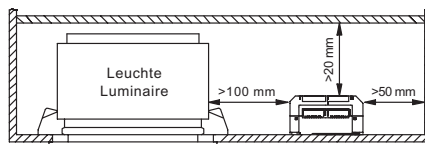

If several ballasts are installed in masts, boxes, etc., measures must be taken to avoid overheating of individual components.

Safety switch off

End of life of the lamps

At the end of their useful life, lamps often cycle on/off. The PCI ballast recognises this condition and switches off the lamp, after three complete on/off cycles and whilst the supply has been unswitched. Complete lamp switch off enables easy identification of a defective lamp in the application. After a change of the faulty lamp and an interruption of the mains supply (mains reset) the ballast will strike the lamp. When there is no lamp in circuit or a defective lamp is connected to the ballast, the ballast will switch off after apr. 25 minutes (3.5 minutes of ignition time).

Overtemperature shutdown

The units shut down at Δt approx. +10 °C compared with tc/ta. A mains reset must be carried out so that the units switch on again.

Overload strength

320 V_{AC} / 1 h

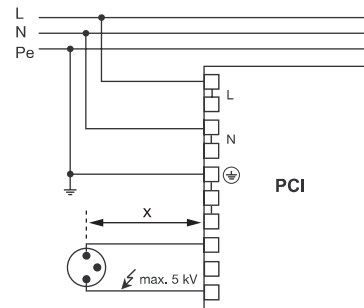

Circuit diagram PCI class 1 applications

Standards

EN 55015 (radio interference)
EN 61000-3-2 (mains harmonics)
EN 61347-2-12
EN 61547 (interference immunity)
CE mark
EMV-VDE mark
ENEC mark

Ballast lumen factor EN 60929 8.1

Type	AC/DC-BLF U = 198–254 V, 25 °C
PCI 0035	1.00
PCI 0070	1.00
PCI 0150	1.00