

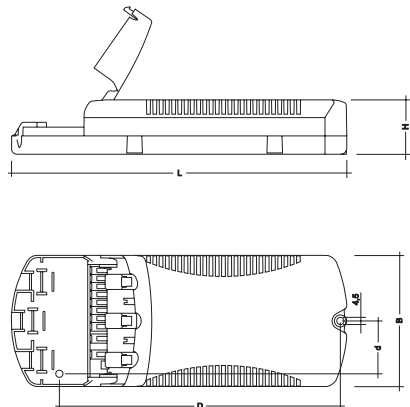

Digital electronic ballasts for remote mounted applications
High pressure discharge lamps

powerCONTROL PCI 35, PCI 70, PCI 150 PRO C021



First electronic ballast for metal halide lamps controlled by a xitec processor. The xitec processor controls the power circuit and the ignition process.

The basic circuit elements are protected by patents. The ballasts were especially designed for mounted applications.

- operate quartz- and ceramic burner lamps
- flicker free light
- stable colour through constant light output
- lamp life increased up to **20 %** ①
- power losses reduced by **25–50 %** ①
- lightweight ①
- no acoustic resonance
- switches off when the lamp is missing or faulty
- increased ignition energy thanks to pulse packages (**PulseControl** technology)

- re-strike time reduced by up to **50 %** ①
- electromagnetic interference during ignition reduced by up to **95 %** ①
- overtemperature cut off
- push-in terminals up to 2.5 mm² for stranded and solid wire
- mains-side through-wiring possible via double mains terminals
- can be used in movable luminaires with plugs (discharge voltage < 34 V after 1 s)
- housing in black polycarbonate (PC), IP20
- integrated terminal cover and cable clamp
- no tools required for installing the terminal cover and cable clamps
- 3 independent strain relief channels
- average service life = 50.000 h (at ta max. with a failure rate ≤ 0.2 % per 1.000 operating hours)

Type		PCI 35 PRO C021	PCI 70 PRO C021	PCI 150 PRO C021
article number		86458606	86458607	86458608
wattage	W	39	73	147
total wattage at ta = 25 °C	W	43.5	79	158.5
mains voltage	V	220–240	220–240	220–240
AC voltage range	V	198–254	198–254	198–254
DC voltage range	V	198–320	198–320	198–320
current	A	0.20	0.35	0.70
mains frequency	Hz	0/50/60	0/50/60	0/50/60
power factor	λ	0.97	0.97	0.97
operating frequency	Hz	145	145	145
max. ignition voltage	kVp	5	5	5
max. cable length to lamp	m/pF	5/400	5/400	5/400
max. ambient temperature ta	°C	65	50	45
min. ambient temperature ta	°C	-25	-25	-25
permissible housing temperature tc ②	°C	80	75	80
diameter of ceiling opening	mm	> 86	> 86	> 86
fixing centres length (D)	mm	125.5	125.5	175.5
fixing centres width (d)	mm	33	33	33
length x width x height	mm	159.4 x 82 x 34	159.4 x 82 x 34	209.4 x 82 x 34
weight	g	250	260	480

① compared to magnetic solutions

② For details see page 3

Installation instructions

Wiring type and cross section

Stranded wire or solid wire up to 2.5 mm² may be used for wiring. Strip 10–11 mm of insulation from the cables to ensure perfect operation of the push-in terminals.

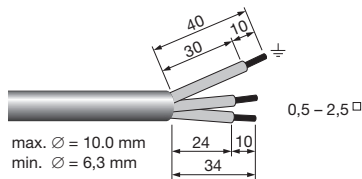

Use one wire for each terminal connector only.

Use each strain relief channel for one cable only.

Fixing conditions

Dry, acidfree, oilfree, fatfree. The maximum ambient temperature must not be exceeded. Is not suitable for fixing in corner. Whenever possible keep the ballast away from hot parts. It helps increasing the lifetime of the ballast.

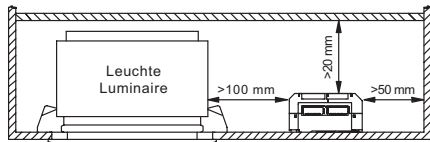

If several ballasts are installed in masts, boxes, etc., measures must be taken to avoid overheating of individual components.

To prevent the use of a wrong lamp type we recommend to mark the luminaire with the correct lamp type that fits to the ballast.

Note on wiring

The length of the lamp wires is limited by the value of cable capacitance. The maximum of 400 pF would enable connection of approximately 5 metres of lamp wire.

In class 1 luminaires it is necessary to earth the ballast and the luminaire, in class 2 luminaires not.

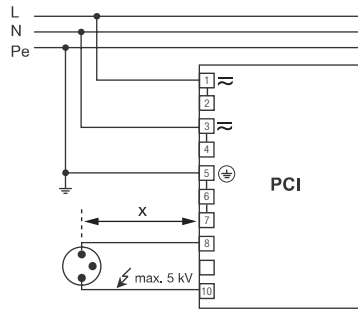

Circuit diagram PCI class 1 application

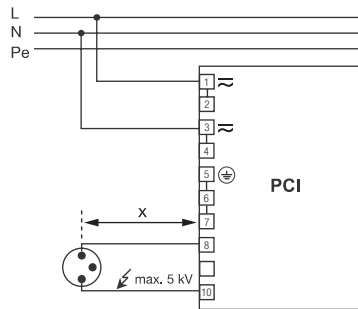

Circuit diagram PCI class 2 application

Radio interference

- Do not cross mains and lamp cables.
- Do not lay mains cables together with lamp cables (ideally they should be 5–10 cm apart).
- Do not lead mains cables too closely along the electronic ballast.
- Twist lamp cables.
- Increase the distance between lamp cables and earthed metal surfaces.
- Keep the mains cable short.
- Parallel runs (x) of mains and lamp cables must be kept as short as possible.

Important advise

When a lamp is changed (at the end of its life), if a lamp is missing or after overtemperature shutdown the mains voltage of the ECG must be disconnected.

Warning – starting voltage up to max. 5 kV!

Not suitable for use with lamps with integral ignitors.

A list of released lamps for the safe operation with PCI can be found on www.tridonicatco.com → Techn. Informations → More Documents → Lamp Matrix for HID

Safety switch off

End of life of the lamps

At the end of their useful life, lamps often cycle on/off. The PCI ballast recognises this condition and switches off the lamp, after three complete on/off cycles and whilst the supply has been unswitched. Complete lamp switch off enables easy identification of a defective lamp in the application. After a change of the faulty lamp and an interruption of the mains supply (mains reset) the ballast will strike the lamp. When there is no lamp in circuit or a defective lamp is connected to the ballast, the ballast will switch off after approx. 25 minutes.

Overtemperature shutdown

The units shut down at Δt approx. +12 °C compared with t_c . A mains reset must be carried out so that the units switch on again.

Overload strength

320 V_{AC} / 1 h
280 V_{AC} / 10 h

Packing quantities

box of 15
40 boxes/pallet
600 pieces/pallet

Standards

EN 55015 (radio interference)
EN 61000-3-2 (mains harmonics)
EN 61347-2-12
EN 61547 (interference immunity)
EN 61167
CE mark
ENEC mark
CQC mark

Ballast lumen factor EN 60929 8.1

Type	AC/DC-BLF
	U = 198–254 V, 25 °C
PCI 35 PRO C021	1.00
PCI 70 PRO C021	1.00
PCI 150 PRO C021	1.00

Harmonic distortion in the mains supply

Type	Ballast
	THD
PCI 35 PRO C021	<10 %
PCI 70 PRO C021	<10 %
PCI 150 PRO C021	<10 %

Loading of automatic circuit breakers

Automatic circuit

breaker type	C10	C13	C16	C20	B10	B13	B16	B20
Installation \varnothing	1.5 mm ²	1.5 mm ²	1.5 mm ²	2.5 mm ²	1.5 mm ²	1.5 mm ²	1.5 mm ²	2.5 mm ²
PCI 35 PRO C021	30	40	50	60	15	20	25	30
PCI 70 PRO C021	14	25	36	42	8	14	18	18
PCI 150 PRO C021	7	14	20	20	4	6	7	7

Temperature range

The t_a temperature value is the basis for specifying the rated life.

The relationship between the t_c temperature and the t_a temperature depends on the design of the luminaire. If the measured t_c temperature is approximately 5 K under the t_c max. temperature the t_a temperature should be checked and, if necessary, measurements should be taken on the critical components (e.g. electrolytic capacitor).

Detailed information is available on request.

PCI PRO C021 is designed for an average life of 50,000 hours under rated conditions, with a failure probability of less than 10 %. This corresponds to an average failure rate of 0.2 % per 1,000 hours of operation.

The specified t_c temperature is the maximum permitted value (rated temperature according to EN 61347-1). Above this safety-related value the thermal cutout protects the device against damage.

The expected lifetime values are shown in the following table. The t_c values are the relevant values here.

Expected lifetime

Lamp power					
35 W	t_a	°C	65	60	55
	t_c	°C	80	75	70
	lifetime	h	50,000	75,000	100,000
70 W	t_a	°C	50	45	40
	t_c	°C	75	70	65
	lifetime	h	50,000	65,000	90,000
150 W	t_a	°C	45	40	35
	t_c	°C	80	75	70
	lifetime	h	55,000	75,000	100,000