

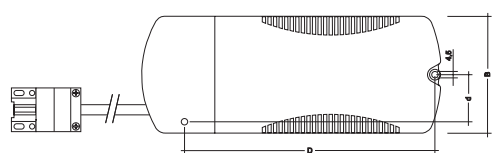

## Digital electronic ballasts for remote mounted applications High pressure discharge lamps

powerCONTROL PCI 35, PCI 70, PCI 150 PRO C521 ST

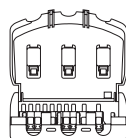
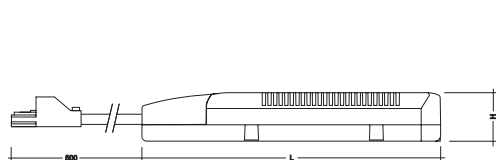

First electronic ballast for metal halide lamps controlled by a xitec processor. The xitec processor controls the power circuit and the ignition process.

The basic circuit elements are protected by patents. The ballasts were especially designed for mounted applications.

- operate quartz- and ceramic burner lamps
- flicker free light
- stable colour through constant light output
- lamp life increased up to **20 %** ①
- power consumption reduced by **25–50 %** ①
- lightweight
- no acoustic resonance
- switches off when the lamp is missing or faulty
- increased ignition energy thanks to pulse packages (**PulseControl** technology)

- re-strike time reduced by up to **50 %** ①
- electromagnetic interference during ignition reduced by up to **95 %** ①
- overtemperature cut off
- push-in terminals up to 2.5 mm<sup>2</sup> for stranded and solid wire
- mains-side through-wiring possible via double mains terminals
- **halogen-free lamp cable with ST-18 socket**
- can be used in movable luminaires with plugs (discharge voltage < 34 V after 1 s)
- housing in black polycarbonate (PC), IP20
- integrated terminal cover and cable clamp
- no tools required for installing the terminal cover and cable clamps
- 3 independent strain relief channels
- average service life = 50.000 h (at ta max. with a failure rate ≤ 0.2 % per 1.000 operating hours)

Type		PCI 35 PRO C521 ST	PCI 70 PRO C521 ST	PCI 150 PRO C521 ST
article number		86458609	86458610	86458611
wattage	W	39	73	147
total wattage at ta = 25 °C	W	43.5	79	158.5
mains voltage	V	220–240	220–240	220–240
AC voltage range	V	198–254	198–254	198–254
DC voltage range	V	198–320	198–320	198–320
current	A	0.20	0.35	0.70
mains frequency	Hz	0/50/60	0/50/60	0/50/60
power factor	λ	0.97	0.97	0.97
operating frequency	Hz	145	145	145
max. ignition voltage	kVp	5	5	5
length of the lamp cable	m	0.5	0.5	0.5
connection type (lamp cable)		ST	ST	ST
max. cable length to lamp	m/pF	5/400	5/400	5/400
max. ambient temperature ta	°C	65	50	45
min. ambient temperature ta	°C	-25	-25	-25
permissible housing temperature tc ②	°C	80	75	80
diameter of ceiling opening	mm	> 86	> 86	> 86
fixing centres length (D)	mm	125.5	125.5	175.5
fixing centres width (d)	mm	33	33	33
length x width x height	mm	159.4 x 82 x 34	159.4 x 82 x 34	209.4 x 82 x 34
weight	g	300	310	530

① compared to magnetic solutions

② For details see page 3

## Installation instructions

### Wiring type and cross section

Stranded wire or solid wire up to 2.5 mm<sup>2</sup> may be used for wiring. Strip 10–11 mm of insulation from the cables to ensure perfect operation of the screw terminals.

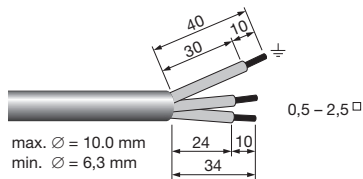

Use one wire for each terminal connector only.

Use each strain relief channel for one cable only.

### Lamp cable connector

Black ST-18 socket



### Terminals

Screw type M3  
Torque 0.5 Nm

### Fixing conditions

Dry, acidfree, oilfree, fatfree. The maximum ambient temperature must not be exceeded. Is not suitable for fixing in corner. Whenever possible keep the ballast away from hot parts. It helps increasing the lifetime of the ballast.

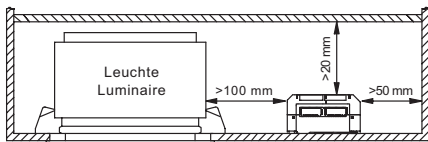

If several ballasts are installed in masts, boxes, etc., measures must be taken to avoid overheating of individual components.

To prevent the use of a wrong lamp type we recommend to mark the luminaire with the correct lamp type that fits to the ballast.

### Loading of automatic circuit breakers

Automatic circuit

breaker type	C10	C13	C16	C20	B10	B13	B16	B20
Installation Ø	1.5 mm <sup>2</sup>	1.5 mm <sup>2</sup>	1.5 mm <sup>2</sup>	2.5 mm <sup>2</sup>	1.5 mm <sup>2</sup>	1.5 mm <sup>2</sup>	1.5 mm <sup>2</sup>	2.5 mm <sup>2</sup>
PCI 35 PRO C521 ST	30	40	50	60	15	20	25	30
PCI 70 PRO C521 ST	14	25	36	42	8	14	18	18
PCI 150 PRO C521 ST	7	14	20	20	4	6	7	7

### Note on wiring

The length of the lamp wires is limited by the value of cable capacitance. The maximum of 400 pF would enable connection of approximately 5 metres of lamp wire.

In class 1 luminaires it is necessary to earth the ballast and the luminaire, in class 2 luminaires not.

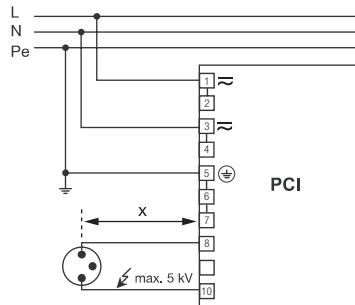

Circuit diagram PCI class 1 application

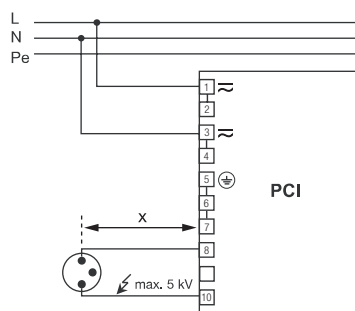

Circuit diagram PCI class 2 application

### Radio interference

- Do not cross mains and lamp cables.
- Do not lay mains cables together with lamp cables (ideally they should be 5–10 cm apart).
- Do not lead mains cables too closely along the electronic ballast.
- Twist lamp cables.
- Increase the distance between lamp cables and earthed metal surfaces.
- Keep the mains cable short.
- Parallel runs (x) of mains and lamp cables must be kept as short as possible.

### Important advise

When a lamp is changed (at the end of its life), if a lamp is missing or after overtemperature shutdown the mains voltage of the ECG must be disconnected.

### Warning – starting voltage up to max. 5 kV!

Not suitable for use with lamps with integral ignitors.

A list of released lamps for the save operation with PCI can be found on [www.tridonicatco.com](http://www.tridonicatco.com) → Techn. Informations → More Documents → Lamp Matrix for HID

### Safety switch off

#### End of life of the lamps

At the end of their useful life, lamps often cycle on/off. The PCI ballast recognises this condition and switches off the lamp, after three complete on/off cycles and whilst the supply has been unswitched. Complete lamp switch off enables easy identification of a defective lamp in the application. After a change of the faulty lamp and an interruption of the mains supply (mains reset) the ballast will strike the lamp. When there is no lamp in circuit or a defective lamp is connected to the ballast, the ballast will switch off after apr. 25 minutes.

#### Overtemperature shutdown

The units shut down at  $\Delta t$  approx. +12 °C compared with  $t_c/t_a$ . A mains reset must be carried out so that the units switch on again.

#### Overload strength

320 V<sub>AC</sub> / 1 h  
280 V<sub>AC</sub> / 10 h

#### Packing quantities

box of 15  
40 boxes/pallet  
600 pieces/pallet

#### Standards

EN 55015 (radio interference)  
EN 61000-3-2 (mains harmonics)  
EN 61347-2-12  
EN 61547 (interference immunity)  
EN 61167  
CE mark  
ENEC mark  
CQC mark

#### Ballast lumen factor

##### EN 60929 8.1

Type	AC/DC-BLF U = 198–254 V, 25 °C
PCI 35 PRO C521 ST	1.00
PCI 70 PRO C521 ST	1.00
PCI 150 PRO C521 ST	1.00

#### Harmonic distortion in the mains supply

Ballast Type	THD
PCI 35 PRO C521 ST	<10 %
PCI 70 PRO C521 ST	<10 %
PCI 150 PRO C521 ST	<10 %

### Temperature range

The  $t_a$  temperature value is the basis for specifying the rated life.

The relationship between the  $t_c$  temperature and the  $t_a$  temperature depends on the design of the luminaire. If the measured  $t_c$  temperature is approximately 5 K under the  $t_c$  max. temperature the  $t_a$  temperature should be checked and, if necessary, measurements should be taken on the critical components (e.g. electrolytic capacitor).

Detailed information is available on request.

PCI PRO C521 ST is designed for an average life of 50,000 hours under rated conditions, with a failure probability of less than 10 %. This corresponds to an average failure rate of 0.2 % per 1,000 hours of operation.

The specified  $t_c$  temperature is the maximum permitted value (rated temperature according to EN 61347-1). Above this safety-related value the thermal cutout protects the device against damage.

The expected lifetime values are shown in the following table. The  $t_c$  values are the relevant values here.

#### Expected lifetime

Lamp power					
35 W	$t_a$	°C	65	60	55
	$t_c$	°C	80	75	70
	lifetime	h	50,000	75,000	100,000
70 W	$t_a$	°C	50	45	40
	$t_c$	°C	75	70	65
	lifetime	h	50,000	65,000	90,000
150 W	$t_a$	°C	45	40	35
	$t_c$	°C	80	75	70
	lifetime	h	55,000	75,000	100,000