

Digital electronic ballasts with digital interface, not dimmable
Metal halide lamps and sodium lamps

powerCONTROL PCIS outdoor FOX B011

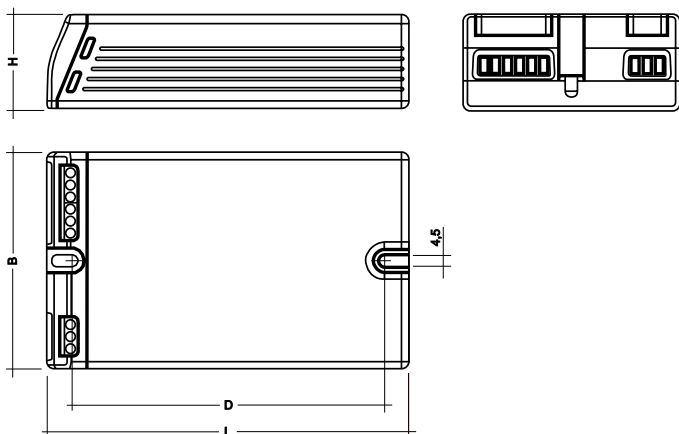

Electronic ballast for metal halide and sodium lamps. Switchable via DALI/DSI signal. The basic circuit elements are patented. The ballasts were especially designed for inbuilding in luminaries.

- operates both metal halide and sodium lamps (PCI 0070 outdoor only metal halide lamps, PCS 0070 outdoor only sodium lamps)
- flicker free light
- stable colour through constant light output
- lamp life increased up to **20 %** ①
- power consumption reduced by **25–50 %** ①
- no acoustic resonance
- switches off when the lamp is missing or faulty
- increased ignition energy thanks to pulse packages (PulseControl technology)
- re-strike time reduced by up to **50 %** ①

- electromagnetic interference during ignition reduced by up to **95 %** ①
- cover of housing: Polycarbonate (PC), black, IP 20
- screw terminals up to 1.5 mm² for flexible wire, up to 2.5 mm² for solid wire
- can be used in movable luminaires with plugs (discharge voltage < 34V after 1 s)
- switchable via mains or via digital interface (DALI/DSI)
- error feed back in DALI mode
- ballasts are potted for optimal protection against dust, moisture and vibration
- enforced insulation
- enforced mains transient protection
- average service life = 60.000 h (at ta max. with a failure rate ≤ 0.2 % per 1.000 operating hours)

Type		PCI 0070 outdoor FOX B011	PCS 0070 outdoor FOX B011	PCIS 0100 outdoor FOX B011	PCIS 0150 outdoor FOX B011	PCIS 0250 outdoor FOX B011
article number		86458590	86458591	86458592	86458593	86458594
lamp wattage	W	73	73	100	147	
circuit wattage at ta = 25 °C	W	81	81	109	161	
standby wattage	W	2.0	2.0	2.0	2.0	2.0
mains voltage	V	220–240	220–240	220–240	220–240	220–240
AC voltage range	V	198–254	198–254	198–254	198–254	198–254
DC voltage range	V	153–320	153–320	153–320	153–320	153–320
current	A	0.35	0.35	0.50	0.70	
DALI current	mA	2.0	2.0	2.0	2.0	2.0
mains frequency	Hz	0/50/60	0/50/60	0/50/60	0/50/60	0/50/60
power factor	λ	0.97	0.97	0.97	0.97	0.97
operating frequency	Hz	145	145	145	145	145
max. ignition voltage	kVp	5	2.5	5	5	5
max. distance from lamp	m/pF	5/400	5/400	5/400	5/400	5/400
max. ambient temperature ta	°C	55	55	55	55	50
min. ambient temperature ta	°C	-25	-25	-25	-25	-25
max. housing temperature tc	°C	70	70	70	75	
fixing centres length (D)	mm	130	130	130	130	130
dimensions length x width x height	mm	150 x 90 x 40	150 x 90 x 40	150 x 90 x 40	150 x 90 x 40	170 x 90 x 60
weight	g	720	720	750	750	

① compared to magnetic solutions

Installation instructions

Wiring type and cross section

Stranded wire with end ferrule with a cross section of 1.5 mm² or solid wire up to 2.5 mm² may be used for wiring. Strip 6 mm of insulation from the cables to ensure perfect operation of the screw terminals.

wire preparation:
0.5 – 2.5 □

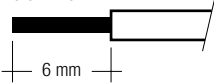

Note on wiring

The length of the lamp wires is limited by the value of cable capacitance. The maximum of 400 pF would enable connection of approximately 5 metres of lamp wire.

To avoid the damage of the control gear, the wiring must be protected against short circuits to earth (sharp edged metal parts, metal cable clips, louver, etc.).

In class 1 luminaires it is necessary to earth the ballast and the luminaire via the earth terminal.

Protection class 2 luminaires do not need an earth connection. Insulation must be provided by the luminaire design.

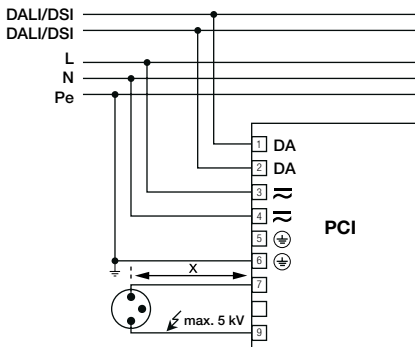

Circuit diagram PCIS class 1 application

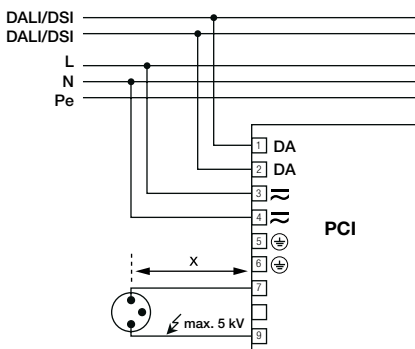

Circuit diagram PCIS class 2 application

Loading of automatic circuit breakers

Automatic circuit breaker type	C10	C13	C16	C20	B10	B13	B16	B20
Installation Ø	1.5 mm ²	1.5 mm ²	1.5 mm ²	2.5 mm ²	1.5 mm ²	1.5 mm ²	1.5 mm ²	2.5 mm ²
PCI 0070 outdoor FOX B011	14	25	36	42	8	14	25	30
PCS 0070 outdoor FOX B011	14	25	36	42	8	14	25	30
PCIS 0100 outdoor FOX B011	10	18	26	30	6	10	13	13
PCIS 0150 outdoor FOX B011	7	14	20	20	4	6	7	7
PCIS 0250 outdoor FOX B011	x	x	x	x	x	x	x	x

Radio interference

- Do not cross mains and lamp cables.
- Do not lay mains cables together with lamp cables (ideally they should be 5–10 cm apart).
- Do not lead mains cables too closely along the electronic ballast.
- Twist lamp cables.
- Increase the distance between lamp cables and earthed metal surfaces.
- Keep the mains cable in the luminaire short.
- Parallel runs (x) of mains and lamp cables must be kept as short as possible.

Mounting recommendation

To ensure optimum heat removal the ECG should be mounted on a metal plate (luminaire body). No insulators between the ECG and the the cooling surface (air, adhesive tape, etc.). Finally, the temperature measurement remains important.

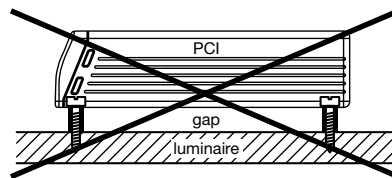
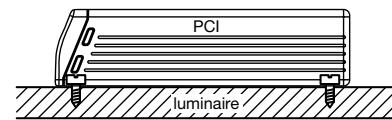

If several ballasts are installed in masts, boxes, etc., measures must be taken to avoid overheating of individual components.

Harmonic distortion in the mains supply

Type	THD
PCI 0070 outdoor FOX B011	<10 %
PCS 0070 outdoor FOX B011	<10 %
PCIS 0100 outdoor FOX B011	<10 %
PCIS 0150 outdoor FOX B011	<10 %
PCIS 0250 outdoor FOX B011	<10 %

Ballast lumen factor

Type	AC/DC-BLF at U = 198–254 V, 25 °C
PCI 0070 outdoor FOX B011	1.00
PCS 0070 outdoor FOX B011	1.00
PCIS 0100 outdoor FOX B011	1.00
PCIS 0150 outdoor FOX B011	1.00
PCIS 0250 outdoor FOX B011	1.00

Safety switch off

End of life of the lamps

At the end of their useful life, lamps often cycle on/off. The PCIS ballast recognises this condition and switches off the lamp, after three complete on/off cycles and whilst the supply has been unswitched. Complete lamp switch-off enables easy identification of a defective lamp in the application. After a change of the faulty lamp and an interruption of the mains supply (mains reset) or send a ON-OFF sequence the ballast will strike the lamp. When there is no lamp in circuit or a defective lamp is connected to the ballast, the ballast will switch off after appr. 25 minutes.

Overtemperature shutdown

The ballasts are equipped with a thermal shutdown to protect against destruction. After shutdown they can be restored with an OFF-ON sequence via DALI/DSI or with a mains reset.

Overload strength

320 V AC / 1 h

Important advise

When a lamp is changed (at the end of its life), if a lamp is missing, or after overtemperature shutdown the mains voltage of the ECG must be disconnected. Alternatively an OFF ON sequence can be sent.

Warning – starting voltage up to max. 5 kV!

Not suitable for use with lamps with integral ignitors. A list of released lamps for the save operation with PCIS can be found on www.tridonicatco.com → Techn. Informations → More Documents → Lamp Matrix for HID

Packing quantities

70–150W	250W
box of 16	box of 10
36 boxes/pallet	36 boxes/pallet
576 pieces/pallet	360 pieces/pallet

Standards

EN 55015 (radio interference)
EN 61000-3-2 (mains harmonics)
EN 61347-2-12
EN 61547 (interference immunity)
CE mark
ENEC mark
IEC 62368 (DALI standard)

Transient protection

Type	L/N-PE	L-N
PCI 0070 outdoor FOX B011	4 kV	6 kV
PCS 0070 outdoor FOX B011	4 kV	6 kV
PCIS 0100 outdoor FOX B011	4 kV	6 kV
PCIS 0150 outdoor FOX B011	4 kV	6 kV
PCIS 0250 outdoor FOX B011	4 kV	6 kV

according to EN 61000-4-5. Additional protection against a single 10 kV pulse.

Control via DALI/DSI

Control input (DA)

Digital DALI/DSI signal can be wired on the terminals DA.

Digital signal DALI/DSI

The control input is non-polar and protected against accidental connection with a mains voltage up to 264V. The control signal is not SELV. Control cable should be installed in accordance with the requirements of low voltage installations. Different functions depending on each module.

Standards (DALI)

HID EVG → device type 2
DALI 0 = 0 % light
DALI > 0 = 100 % light

Programmable parameters

- Groups 1–16
- Scenes 1–16 (values 0 % / 100 % / MASK)
- Power On Level (values 0 % / 100 %)
- System Failure Level (values 0 % / 100 %)

Queries

via DALI standard:

- Lamp wattage (values yes/no)
- Lamp error (values yes/no)

via TridonicAtco configTOOL:

- Lamp type
- Device type
- Article number
- Production date
- Serial number
- Software version
- Commissioning

OEM Memory Bank

The customer can store additional luminaire information in the ECG (Memory Bank 1), such as luminaire type and article number. Data is written to Memory Bank 1 in accordance with DALI standard IEC 62368.

Commissioning of PCIS outdoor FOX ballasts

Because of the special characteristics of HID light sources, PCIS outdoor FOX ballasts (Device Type 2) cannot be addressed in the same way as conventional DALI ballasts for fluorescent or halogen lamps for example. For visualisation during the grouping phase the HID lamps must remain switched off before and during the addressing phase as they can only be properly ignited in the cold state. Dimmed operation of these lamps is not recommended, which also calls for different handling during commissioning.

TridonicAtco recommends configTOOL ≥ V1.5 software for commissioning PCIS outdoor FOX ballasts (download from www.tridonicatco.com → Services → Download → Software).

IMPORTANT: Other DALI controllers can only be used for commissioning if they handle DALI Device Type 2 units appropriately (see Requirements of control products).

Requirements of control products

Initialization/addressing phase:

INITIALIZE	(This command must be sent first)
...	When the INITIALIZE command is sent, PCIS outdoor FOX devices change
...	
...	
RECALL MIN LEVEL	the RECALL MIN value to
...	0 % → devices switch off/remain switched off
...	
...	
TERMINATE	(Last command in the initialization phase)
	When the TERMINATE command is sent, PCIS outdoor FOX changes the RECALL MIN value back to 40 % (100 % light)

The high ignition voltage of high pressure lamps can lead to interferences. During the ignition time the communication can be disturbed. Therefore the ballast might not react during the ignition phase. This has to be considered especially when using gateways.

Realisation with TridonicAtco controls

	Commissioning	Operation
DALI GC		✓
x-touch PANEL	✓	✓
x-touch BOX	✓	✓
DALI TOUCH PANEL		✓
Software config TOOL	✓	✓

Overview – commissioning cycle with configTOOL ≥ V1.5

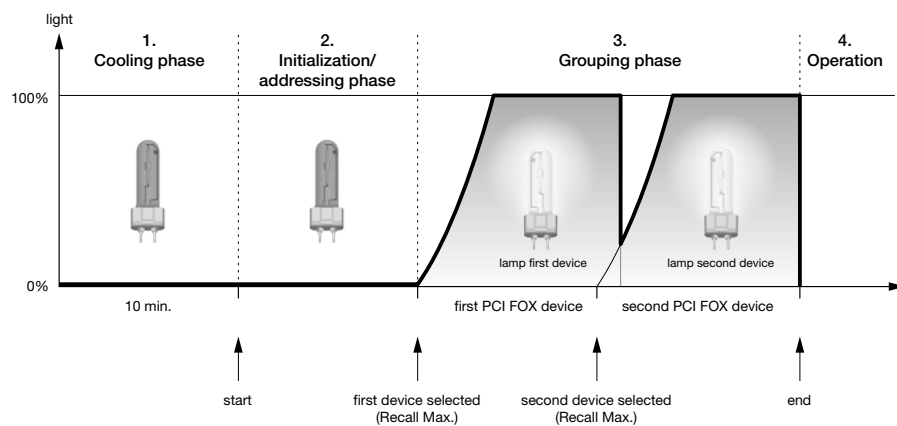

Commissioning comparison table

	DALI HID ballast PCIS outdoor FOX	Standard DALI ballast e.g. PCA Excel one4all
Before commissioning the installation	Devices must have been switched off for at least 10 minutes!	–
Initialisation and addressing phase	Devices remain switched off	<ul style="list-style-type: none"> • Devices fade to minimum value • On successful addressing the devices fade up to 100 % • At the end of the addressing phase the devices fade down to the minimum value
Visualisation in the grouping phase	<ul style="list-style-type: none"> • Selected device starts the lamp at 100 % • If a different device is selected the previously selected device switches off with a maximum delay of 10 s <p>Visualisation/grouping is not possible with hot HID lamps!</p>	<ul style="list-style-type: none"> • Selected device fades from minimum value to 100 % • If a different device is selected the previously selected device fades to the minimum value
Operation	Devices can be controlled/operated with other DALI/DSI control products	Devices can be controlled/operated with other DALI/DSI control products

Step-by-step commissioning with configTOOL ≥ V1.5

1. Cooling phase

HID EVG → Device Type 2

The lighting must have been switched off before start-up for at least 10 min.

(visualization/grouping is not possible with hot lamps)

2. Initialisation and addressing phase

- Launch DALI configTOOL and select the DALI interface
- Go to the “DALI Device Programmer” tab
- Click on “Search Devices” and follow the on-screen instructions.

PCIS outdoor FOX devices remain dark during the entire addressing phase. In contrast, DALI devices for fluorescent lamps, LEDs and incandescent lamps fade down to their minimum value and go to 100 % during the addressing phase. At the end of the addressing phase they fade back to their minimum value.

3. Visualisation in the grouping phase

- Activate the “Enable optical selection feedback” by ticking the checkbox.
- If a PCIS outdoor FOX device (Device Type 2, special symbol) is selected in configTOOL the appropriate device switches on. It remains on until a different DALI device is selected in the system.
→ PCIS outdoor FOX then switches off after a maximum delay of 10 seconds.

4. Operation

- PCIS outdoor FOX devices can be switched powerless with a broadcast signal (DALI or DSI, without addressing of the devices)
- PCIS outdoor FOX devices can be addressed and operated individually or in groups with a DALI signal. For examples with TridonicAtco controls please see matrix above.