

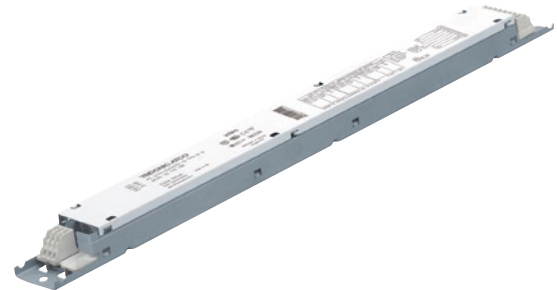

## Electronic ballasts

## Linear and compact lamps T5, T8, TC-L, TC-F, T5c

## PC T5 PRO-M Ip 14–80 W 220–240 V 50/60/0 Hz

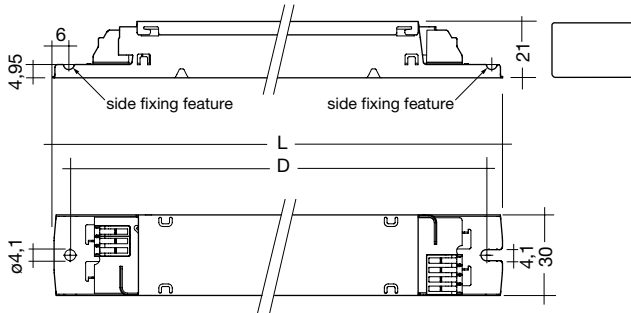

- defined lamp warm start within 0.5 s
- constant light output independent of fluctuations in mains voltage
- average service life = 50,000 h (at ta max. with a failure rate  $\leq 0.2\%$  per 1,000 operating hours)
- AC voltage range 198–264 V
- DC voltage range 176–280 V, (lamp start  $\geq 198$  V DC)
- overvoltage protection 320 V AC, 1 h
- overvoltage indication starting at input voltage  $\geq 306$  V AC
- undervoltage protection (shut down)  $< 150$  V AC / 176 V DC
- operating frequency  $\geq 40$  kHz
- multiple lamp type operation
- integrated lamp detection
- suitable for automatic and manual wiring with insulation displacement connector (IDC)
- wide operating temperature range (values see table)
- suitable for use in emergency lighting installations in accordance with EN 50172
- safe switch off of defective lamps
- automatic re-start after lamp change
- suitable for luminaires with protection class 1 and protection class 2
- Ingress protection IP 20
- thermal protection according to EN 61347-2-3 C5e

**Packaging:**

box of 10  
76 cartons/pallet  
760 pieces/pallet

**Certified:**

EN 55015: 2006 + A1: 2007  
EN 61347-2-4  
EN 61347-2-3  
EN 60925  
EN 60929  
EN 61000-3-2  
EN 61547  
in accordance with EN 50172  
IEC 68-2-64 Fh  
IEC 68-2-29 Eb  
IEC 68-2-30

**Ballast dimensions**

type	article number	length		weight
		L mm	D mm	
PC 1/14–35/24/39 T5 PRO-M Ip 220–240 V 50/60/0 Hz	22176182	360	350	0,25
PC 1/14–35/49/54 T5 PRO-M Ip 220–240 V 50/60/0 Hz	22176183	360	350	0,25
PC 1/14–35/49/80 T5 PRO-M Ip 220–240 V 50/60/0 Hz	22176184	360	350	0,26
PC 2/14–21/24/39 T5 PRO-M Ip 220–240 V 50/60/0 Hz	22176185	360	350	0,27
PC 2/14–35/49/54 T5 PRO-M Ip 220–240 V 50/60/0 Hz	22176186	360	350	0,27

**Ballast/lamp combinations**

type	T5HE				T5HO					T8				TC-L					TC-F			T5c				
	14 W	21 W	28 W	35 W	24 W	39 W	49 W	54 W	80 W	18 W	30 W	36 W	58 W	18 W	24 W	36 W	40 W	55 W	80 W	18 W	24 W	36 W	22 W	40 W	55 W	
PC 1/14–35/24/39 T5 PRO-M Ip	•	•	•	•	•	•				•	•	•		•	•	•	•			•	•	•	•	•		
PC 1/14–35/49/54 T5 PRO-M Ip	•	•	•	•			•	•				•									•	•	•	•	•	
PC 1/14–35/49/80 T5 PRO-M Ip	•	•	•	•			•		•									•	•						•	
PC 2/14–21/24/39 T5 PRO-M Ip	•	•			•	•				•		•		•	•	•	•			•	•	•	•	•		
PC 2/14–35/49/54 T5 PRO-M Ip	•	•	•	•			•	•				•								•	•	•	•	•		

**T5 lamp overview, same length**

	length	type: high efficiency HE (FH)	type: high output HO (FO)
	549 mm	14 W	24 W
	849 mm	21 W	39 W
	1,149 mm	28 W	54 W
	1,449 mm	35 W	49 W / 80 W

## Electronic ballasts

### Linear and compact lamps T5, T8, TC-L, TC-F, T5c



#### PC PRO-M with xitec processor

Is the very latest in lighting management design technology. The lamp friendly warm start is delivering maximum lamp life and enables high switching frequency applications. Smallest power loss and new freedom in the lamp design thanks to convincing thermal management.



#### Multi-lamp

Multi-lamp functionality comprises an additional circuit that automatically detects lamps before they are ignited. After detection the predefined operating parameters stored in an internal memory are retrieved and activated and the light source is then started. This enables a wide variety of lamp types to be operated on only one device.



#### Smart Heating

Innovative heating circuit. Reduced filament heating after lamp ignition.



#### Energy class CELMA EEI = A2

PC T5 PRO-M Ip ignition technology (smart heating) optimises lamp start and ensures no energy is wasted. After the lamp has struck the filament heating is reduced automatically to a defined minimum value. This reduction in filament heating, saves energy, yet maintains the proper operating conditions for the lamp. The lamp is always operated within specification.

#### Ambient Temperature

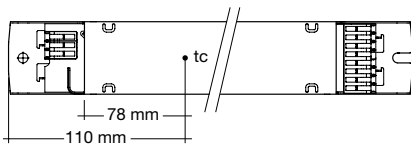

The nominal  $t_a$  and  $t_c$  point are related to the ballast life duration.

The relation of  $t_c$  to  $t_a$  temperature depends also on the luminaire design. If the measured  $t_c$  temperature is approx. 5 K below  $t_c$  max.,  $t_a$  temperature should be checked and eventually critical components (e.g. ELCAP) measured.

Detailed information on request.

PC T5 PRO-M Ip is designed for an average service life of 50,000 hours under reference conditions and with a failure probability of less than 10 %. This corresponds to an average failure rate of 0.2 % for every 1,000 hours of operation.

#### Maximum loading of automatic circuit breakers

Automatic circuit breaker type	C10	C13	C16	C20	B10	B13	B16	B20
Installation $\varnothing$	1.5 mm <sup>2</sup>	1.5 mm <sup>2</sup>	2.5 mm <sup>2</sup>	4.0 mm <sup>2</sup>	1.5 mm <sup>2</sup>	1.5 mm <sup>2</sup>	1.5 mm <sup>2</sup>	2.5 mm <sup>2</sup>
PC 1/14-35/24/39 T5 PRO-M Ip	32	42	50	60	16	21	25	30
PC 1/14-35/49/54 T5 PRO-M Ip	32	42	50	60	16	21	25	30
PC 1/14-35/49/80 T5 PRO-M Ip	14	18	22	26	7	9	11	13
PC 2/14-21/24/39 T5 PRO-M Ip	28	34	40	48	14	17	20	24
PC 2/14-35/49/54 T5 PRO-M Ip	14	18	22	26	7	9	11	13



#### Lamp starting characteristics

Warm start  
Starting time 0.5 secs with AC and DC operation  
Cathode heating will be reduced after preheat time

#### AC operation

Mains voltage:  
220–240 V 50/60 Hz  
198–264 V 50/60 Hz including safety tolerance ( $\pm 10$  %)  
202–254 V 50/60 Hz including performance tolerance (+6 % / -8 %)

#### DC operation

220–240 V 0 Hz  
198–280 V 0 Hz certain lamp start  
176–280 V 0 Hz operating range  
Light output level in DC operation: 100 %

#### Emergency lighting

Use in emergency lighting installations according to EN 50172 or for emergency luminaires according to EN 61347-2-3 appendix J.  
Instant start after mains interruption < 0.5 s



#### Intelligent Voltage Guard

Intelligent Voltage Guard is the name of the new electronic monitor from TridonicAtco. This innovative feature of the PC PRO-M family of control gear from TridonicAtco immediately shows if the mains voltage rises above or falls below certain thresholds. Measures can then be taken quickly to prevent damage to the control gear.

- If the mains voltage rises above 306 V the lamps start flashing on and off.
- This signal “demands” disconnection of the power supply to the lighting system.
- If the mains voltage falls below 150 V the control gear automatically disconnects the lamp circuit to protect the control gear from being irreparably damaged.

### Wiring advice

The lead length is dependant on the capacitance of the cable.  
For safety reasons, the PC T5 PRO-M Ip must only be earthed in the case of a safety class 1 luminaire.  
Earthing is not required for the device to operate. Connection to earth reduces radio interference.

With standard solid wire 0.5/0.75 mm<sup>2</sup> the capacitance of the lead is 30–80 pF/m. This value is influenced by the way the wiring is made.

- keep lamp wires short
- lamp connection with multi-lamp ballasts should be made with symmetrical wiring
- for 1 and 2 lamp ballasts: hot leads 9, 10, 15, 16 and cold leads 11, 12, 13, 14 should be separated as much as possible

Ballast Type	Terminal		Maximum capacitance allowed	
	Cold	Hot	Cold	Hot
PC 1/14-35/24/39 T5 PRO-M Ip	11, 12	9, 10	200 pF	100 pF
PC 1/14-35/49/54 T5 PRO-M Ip	11, 12	9, 10	200 pF	100 pF
PC 1/14-35/49/80 T5 PRO-M Ip	11, 12	9, 10	200 pF	100 pF
PC 2/14-21/24/39 T5 PRO-M Ip	11, 12, 13, 14	9, 10, 15, 16	200 pF	100 pF
PC 2/14-35/49/54 T5 PRO-M Ip	11, 12, 13, 14	9, 10, 15, 16	200 pF	100 pF

### Installation instructions



#### IDC interface

- solid wire with a cross section of 0.5 mm<sup>2</sup> according to the specification from WAGO
- alternatively a flexible lead with a cross section of 0.75 mm<sup>2</sup>

#### Horizontal interface

- solid wire with a cross section of 0.5–0.75 mm<sup>2</sup> according to the specification from WAGO
- solid wire with a cross section of 1.0 mm<sup>2</sup> with an insulation diameter up to 2.5 mm
- strip 9 mm of insulation from the cables to ensure perfect operation of the terminals
- Loosen wire through twisting and pulling

wire preparation:  
0.5–0.75 □

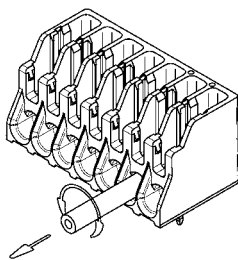
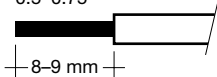

Loosen wire through twisting and pulling

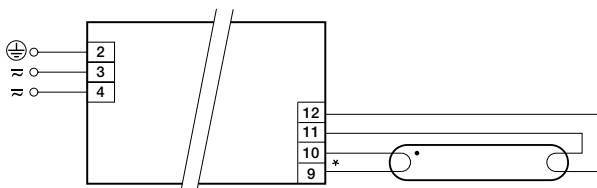

\* leads 9, 10 max. 1.0 m (< 100 pF)  
leads 11, 12 max. 2.0 m (< 200 pF)  
SK I - luminaires: earth of ballast housing required (according to IEC 598)  
SK II - luminaires: no earth required

PC 1/14-35/24/39 T5 PRO-M Ip  
PC 1/14-35/49/54 T5 PRO-M Ip  
PC 1/14-35/49/80 T5 PRO-M Ip

### RFI

TridonicAtco ballasts are RFI protected in accordance with EN 55015: 2006 + A1: 2007.  
To operate the luminaire correctly and to minimise RFI we recommend the following instructions:

- Connection to the lamps of the “hot leads” must be kept as short as possible (marked with \*)
- Mains leads should be kept apart from lamp leads (ideally 5–10 cm distance)
- Do not run mains leads adjacent to the electronic ballast
- Twist the lamp leads
- Keep the distance of lamp leads from the metal work as large as possible
- Ballast must be earthed, either over the terminal or over the mounting screw of the ballast
- Mains wiring to be twisted when through wiring
- Keep the mains leads inside the luminaire as short as possible

### Side fixing feature

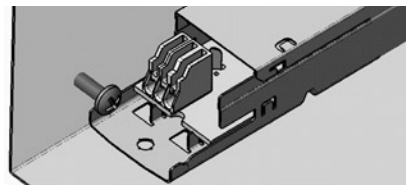

Screw M4, screw head diameter 8–10 mm

### Defective lamp

If a lamp is defective, the ballast switches off and goes into standby. There is an automatic restart once the lamp has been changed.

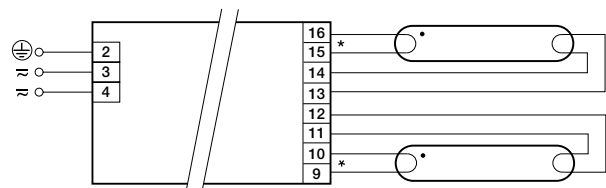

\* leads 9, 10, 15, 16 max. 1.0 m (< 100 pF)  
leads 11, 12, 13, 14 max. 2.0 m (< 200 pF)  
SK I - luminaires: earth of ballast housing required (according to IEC 598)  
SK II - luminaires: no earth required

PC 2/14-21/24/39 T5 PRO-M Ip  
PC 2/14-35/49/54 T5 PRO-M Ip

## Electronic ballasts

### Linear and compact lamps T5, T8, TC-L, TC-F, T5c

#### Technical Data PC 1/14-35/24/39 T5 PRO-M Ip

type	wattage W	lamp type	lamp- power W	circuit power W ①	Celma- class EEI	current at 50 Hz		λ at 50 Hz		tc point °C	temperature range ta °C
						220V A	240V A	220V	240V		
PC 1/14-35/24/39 T5 PRO-M Ip 220–240 V 50/60/0 Hz	1x14	T5	14.0	16.5	A2	0.09	0.08	0.89c	0.85c	75	-25 → +65
	1x21		20.6	23.0	A2	0.11	0.11	0.92c	0.90c	75	-25 → +65
	1x28		27.9	31.0	A2	0.15	0.14	0.97	0.95	75	-25 → +60
	1x35		35.5	39.0	A2	0.18	0.17	0.98	0.96	75	-25 → +60
	1x24		22.5	25.0	A2	0.12	0.11	0.97	0.95	75	-25 → +60
	1x39		38.0	41.0	A2	0.19	0.18	0.98	0.96	75	-25 → +60
	1x18	T8	17.0	18.5	A2	0.09	0.09	0.91c	0.89c	75	-25 → +65
	1x30		26.5	29.5	A2	0.14	0.13	0.97	0.95	75	-25 → +65
	1x36		32.0	34.5	A2	0.16	0.15	0.97	0.95	75	-25 → +65
	1x18	TC-L	15.5	17.0	A2	0.09	0.08	0.91c	0.89c	75	-25 → +65
	1x24		23.0	24.5	A2	0.11	0.11	0.97	0.95	75	-25 → +65
	1x36		30.5	33.0	A2	0.15	0.14	0.97	0.95	75	-25 → +65
	1x40		40.0	42.0	A2	0.19	0.18	0.98	0.96	75	-25 → +60
	1x18	TC-F	15.5	16.5	A2	0.08	0.08	0.91c	0.89c	75	-25 → +65
	1x24		23.0	25.0	A2	0.12	0.11	0.97	0.95	75	-25 → +65
	1x36		30.5	33.0	A2	0.15	0.14	0.97	0.95	75	-25 → +65
	1x22	T5c	23.5	25.5	A2	0.12	0.11	0.97	0.95	75	-25 → +65
	1x40		40.0	43.0	A2	0.20	0.19	0.98	0.96	75	-25 → +60

① measured according to EN 50294

#### Mains currents in DC operation

type	wattage W	lamp type	mains current at Un = 220 VDC	mains current at Un = 240 VDC
PC 1/14-35/24/39 T5 PRO-M Ip 220–240 V 50/60/0 Hz	1x14	T5	85 mA	80 mA
	1x21		110 mA	110 mA
	1x28		150 mA	140 mA
	1x35		180 mA	170 mA
	1x24		120 mA	110 mA
	1x39		190 mA	180 mA
	1x18	T8	90 mA	87 mA
	1x30		140 mA	130 mA
	1x36		160 mA	150 mA
	1x18	TC-L	85 mA	80 mA
	1x24		110 mA	107 mA
	1x36		150 mA	140 mA
	1x40		190 mA	180 mA
	1x18	TC-F	80 mA	77 mA
	1x24		115 mA	110 mA
	1x36		150 mA	140 mA
	1x22	T5c	120 mA	110 mA
	1x40		200 mA	190 mA

#### Harmonic distortion in the mains supply

type	wattage W	lamp type	THD at 230 V / 50 Hz
PC 1/14-35/24/39 T5 PRO-M Ip 220–240 V 50/60/0 Hz	1x14	T5	< 25 %
	1x21		< 15 %
	1x28		< 10 %
	1x35		< 10 %
	1x24		< 10 %
	1x39		< 10 %
	1x18	T8	< 20 %
	1x30		< 10 %
	1x36		< 10 %

**Harmonic distortion in the mains supply**

type	wattage W	lamp type	THD at 230 V / 50 Hz
PC 1/14-35/24/39 T5 PRO-M Ip 220–240 V 50/60/0 Hz	1x18	TC-L	< 20 %
	1x24		< 15 %
	1x36		< 10 %
	1x40		< 10 %
	1x18	TC-F	< 20 %
	1x24		< 15 %
	1x36		< 15 %
	1x22	T5c	< 15 %
	1x40		< 10 %

**Output voltage**

type	U <sub>out</sub>
PC 1/14-35/24/39 T5 PRO-M Ip 220–240 V 50/60/0 Hz	430 V

**Ballast lumen factor  
EN 60929 8.1**

type	wattage W	lamp type	AC/DC-BLF at U = 198–254 V, 25 °C
PC 1/14-35/24/39 T5 PRO-M Ip 220–240 V 50/60/0 Hz	1x14	T5	1.00
	1x21		1.00
	1x28		1.00
	1x35		1.00
	1x24		1.05
	1x39		0.95
	1x18	T8	1.05
	1x30		1.10
	1x36		1.00
	1x18	TC-L	1.00
	1x24		1.05
	1x36		0.95
	1x40		1.00
	1x18	TC-F	1.00
	1x24		1.05
	1x36		0.95
	1x22	T5c	1.05
	1x40		1.00

**Electronic ballasts**  
**Linear and compact lamps T5, T8, TC-L, TC-F, T5c**

**Technical Data PC 1/14-35/49/54 T5 PRO-M Ip**

type	wattage W	lamp type	lamp- power W	circuit power W ①	Celma- class EEI	current at 50 Hz		λ at 50 Hz		tc point °C	temperature range ta °C
						220V A	240V A	220V	240V		
PC 1/14-35/49/54 T5 PRO-M Ip 220–240 V 50/60/0 Hz	1x14	T5	14.0	16.5	A2	0.085	0.08	0.89c	0.85c	75	-25 → +65
	1x21		20.6	23.0	A2	0.12	0.11	0.92c	0.90c	75	-25 → +60
	1x28		27.9	31.0	A2	0.15	0.14	0.97	0.95	75	-25 → +60
	1x35		35.5	39.0	A2	0.18	0.17	0.98	0.96	75	-25 → +55
	1x49		49.2	52.5	A2	0.24	0.23	0.99	0.97	75	-25 → +55
	1x54		54.1	58.0	A2	0.27	0.25	0.99	0.97	75	-25 → +55
	1x58	T8	50.0	54.0	A2	0.25	0.23	0.99	0.97	75	-25 → +55

① measured according to EN 50294

**Mains currents in DC operation**

type	wattage W	lamp type	mains current at Un = 220 VDC	mains current at Un = 240 VDC
PC 1/14-35/49/54 T5 PRO-M Ip 220–240 V 50/60/0 Hz	1x14	T5	85 mA	80 mA
	1x21		120 mA	110 mA
	1x28		150 mA	140 mA
	1x35		180 mA	170 mA
	1x49		240 mA	230 mA
	1x54		270 mA	250 mA
	1x58	T8	250 mA	232 mA

**Harmonic distortion in the mains supply**

type	wattage W	lamp type	THD at 230 V / 50 Hz
PC 1/14-35/49/54 T5 PRO-M Ip 220–240 V 50/60/0 Hz	1x14	T5	< 20 %
	1x21		< 15 %
	1x28		< 10 %
	1x35		< 10 %
	1x49		< 10 %
	1x54		< 10 %
	1x58	T8	< 10 %

**Output voltage**

type	U <sub>out</sub>
PC 1/14-35/49/54 T5 PRO-M Ip 220–240 V 50/60/0 Hz	300 V

**Ballast lumen factor**  
**EN 60929 8.1**

type	wattage W	lamp type	AC/DC-BLF at U = 198–254 V, 25 °C
PC 1/14-35/49/54 T5 PRO-M Ip 220–240 V 50/60/0 Hz	1x14	T5	1.00
	1x21		1.00
	1x28		1.00
	1x35		1.00
	1x49		1.00
	1x54		1.00
	1x58	T8	1.00

**Technical Data PC 1/14-35/49/80 T5 PRO-M Ip**

type	wattage W	lamp type	lamp- power W	circuit power W ①	Celma- class EEI	current at 50Hz		λ at 50Hz		tc point °C	temperature range ta °C
						220V A	240V A	220V	240V		
PC 1/14-35/49/80 T5 PRO-M Ip 220–240 V 50/60/0 Hz	1x14	T5	14.0	16.5	A2	0.085	0.08	0.89c	0.85c	75	-25 → +60
	1x21		20.6	24.0	A2	0.12	0.11	0.92c	0.90c	75	-25 → +60
	1x28		27.9	31.5	A2	0.15	0.14	0.97	0.95	75	-25 → +60
	1x35		35.5	39.0	A2	0.18	0.17	0.98	0.96	70	-25 → +55
	1x49		49.2	53.5	A2	0.25	0.23	0.99	0.97	75	-25 → +55
	1x80		79.8	85.0	A2	0.39	0.37	0.99	0.97	75	-25 → +55
	1x55	TC-L	55.0	59.0	A2	0.27	0.25	0.99	0.97	75	-25 → +55
	1x80		80.0	84.0	A2	0.39	0.36	0.99	0.97	75	-25 → +55
	1x55		T5c	55.0	59.5	A2	0.28	0.26	0.99	0.97	75

① measured according to EN 50294

**Mains currents in DC operation**

type	wattage W	lamp type	mains current at Un = 220 VDC	mains current at Un = 240 VDC
PC 1/14-35/49/80 T5 PRO-M Ip 220–240 V 50/60/0 Hz	1x14	T5	85 mA	80 mA
	1x21		120 mA	110 mA
	1x28		150 mA	140 mA
	1x35		180 mA	170 mA
	1x49		250 mA	230 mA
	1x80		390 mA	370 mA
	1x55	TC-L	270 mA	250 mA
	1x80		390 mA	360 mA
	1x55		T5c	275 mA

**Harmonic distortion in the mains supply**

type	wattage W	lamp type	THD at 230 V / 50 Hz
PC 1/14-35/49/80 T5 PRO-M Ip 220–240 V 50/60/0 Hz	1x14	T5	< 25 %
	1x21		< 15 %
	1x28		< 10 %
	1x35		< 10 %
	1x49		< 10 %
	1x80		< 10 %
	1x55	TC-L	< 10 %
	1x80		< 10 %
	1x55		T5c

**Output voltage**

type	U <sub>out</sub>
PC 1/14-35/49/80 T5 PRO-M Ip 220–240 V 50/60/0 Hz	350 V

**Ballast lumen factor  
EN 60929 8.1**

type	wattage W	lamp type	AC/DC-BLF at U = 198–254 V, 25 °
PC 1/14-35/49/80 T5 PRO-M Ip 220–240 V 50/60/0 Hz	1x14	T5	1.00
	1x21		1.00
	1x28		1.00
	1x35		1.00
	1x49		1.00
	1x80		1.00
	1x55	TC-L	1.00
	1x80		1.00
	1x55		T5c

Technical Data PC 2/14-21/24/39 T5 PRO-M Ip

type	wattage W	lamp type	lamp- power W	circuit power W ①	Celma- class EEI	current at 50Hz		λ at 50Hz		tc point °C	temperature range ta °C
						220V A	240V A	220V	240V		
PC 2/14-21/24/39 T5 PRO-M Ip 220–240 V 50/60/0 Hz	2x14	T5	28.0	32.0	A2	0.15	0.14	0.96c	0.94c	75	-25 → +60
	2x21		41.2	47.0	A2	0.22	0.21	0.97	0.95	70	-25 → +50
	2x24		45.0	49.0	A2	0.23	0.21	0.98	0.96	75	-25 → +55
	2x39		76.0	82.0	A2	0.38	0.35	0.99	0.97	75	-25 → +55
	2x18	T8	32.0	35.0	A2	0.17	0.16	0.96c	0.94c	75	-25 → +60
	2x36		64.0	68.5	A2	0.32	0.30	0.98	0.96	75	-25 → +55
	2x18	TC-L	32.0	35.0	A2	0.17	0.16	0.96c	0.94c	75	-25 → +60
	2x24		46.0	47.5	A2	0.22	0.21	0.98	0.96	75	-25 → +55
	2x36		61.0	67.5	A2	0.31	0.29	0.98	0.96	75	-25 → +55
	2x40		80.0	84.5	A2	0.39	0.36	0.99	0.97	75	-25 → +55
	2x18	TC-F	32.0	34.0	A2	0.16	0.15	0.96c	0.94c	75	-25 → +60
	2x24		46.0	47.5	A2	0.22	0.21	0.98	0.96	75	-25 → +55
	2x36		61.0	67.5	A2	0.31	0.29	0.98	0.96	75	-25 → +55
	2x22	T5c	46.5	48.0	A2	0.22	0.21	0.98	0.96	75	-25 → +60
	2x40		80.0	85.0	A2	0.39	0.37	0.99	0.97	75	-25 → +55

① measured according to EN 50294

Mains currents in DC operation

type	wattage W	lamp type	mains current at Un = 220 VDC	mains current at Un = 240 VDC
PC 2/14-21/24/39 T5 PRO-M Ip 220–240 V 50/60/0 Hz	2x14	T5	150 mA	140 mA
	2x21		220 mA	210 mA
	2x24		230 mA	210 mA
	2x39		380 mA	350 mA
	2x18	T8	170 mA	160 mA
	2x36		320 mA	300 mA
	2x18	TC-L	170 mA	160 mA
	2x24		220 mA	210 mA
	2x36		310 mA	290 mA
	2x40		390 mA	360 mA
	2x18	TC-F	160 mA	150 mA
	2x24		220 mA	210 mA
	2x36		310 mA	290 mA
	2x22	T5c	220 mA	210 mA
	2x40		390 mA	370 mA

Harmonic distortion in the mains supply

type	wattage W	lamp type	THD at 230 V / 50 Hz
PC 2/14-21/24/39 T5 PRO-M Ip 220–240 V 50/60/0 Hz	2x14	T5	< 10 %
	2x21		< 10 %
	2x24		< 10 %
	2x39		< 10 %
	2x18	T8	< 20 %
	2x36		< 10 %
	2x18	TC-L	< 20 %
	2x24		< 15 %
	2x36		< 10 %
	2x40		< 10 %
	2x18	TC-F	< 20 %
	2x24		< 15 %
	2x36		< 10 %
	2x22	T5c	< 15 %
	2x40		< 10 %

**Output voltage**

type	U <sub>out</sub>
PC 2/14-21/24/39 T5 PRO-M Ip 220–240 V 50/60/0 Hz	350 V

**Ballast lumen factor  
EN 60929 8.1**

type	wattage W	lamp type	AC/DC-BLF at U = 198–254 V, 25 °C
PC 2/14-21/24/39 T5 PRO-M Ip 220–240 V 50/60/0 Hz	2x14	T5	1.00
	2x21		1.00
	2x24		1.05
	2x39		0.95
	2x18	T8	1.00
	2x36		1.00
	2x18	TC-L	1.00
	2x24		1.05
	2x36		0.95
	2x40	TC-F	1.00
	2x18		1.05
	2x24		0.95
	2x22	T5c	1.05
	2x40		1.00

## Electronic ballasts

### Linear and compact lamps T5, T8, TC-L, TC-F, T5c

#### Technical Data PC 2/14-35/49/54 T5 PRO-M Ip

type	wattage W	lamp type	lamp- power W	circuit power W ①	Celma- class EEI	current at 50 Hz		$\lambda$ at 50 Hz		tc point °C	temperature range ta °C
						220V A	240V A	220V	240V		
PC 2/14-35/49/54 T5 PRO-M Ip 220–240 V 50/60/0 Hz	2x14	T5	28.0	32.0	A2	0.15	0.14	0.96c	0.94c	75	-25 → +60
	2x21		41.2	45.0	A2	0.21	0.20	0.97	0.95	75	-25 → +60
	2x28		55.8	61.0	A2	0.28	0.26	0.98	0.96	75	-25 → +55
	2x35		71.0	76.5	A2	0.35	0.33	0.98	0.96	70	-25 → +50
	2x49		98.4	105.0	A2	0.48	0.45	0.99	0.97	75	-25 → +50
	2x54		108.2	117.0	A2	0.54	0.50	0.99	0.97	75	-25 → +50
	2x58	T8	100.0	108.0	A2	0.50	0.46	0.99	0.97	70	-25 → +50

① measured according to EN 50294

#### Mains currents in DC operation

type	wattage W	lamp type	mains current at Un = 220 VDC	mains current at Un = 240 VDC
PC 2/14-35/49/54 T5 PRO-M Ip 220–240 V 50/60/0 Hz	2x14	T5	150 mA	140 mA
	2x21		210 mA	200 mA
	2x28		280 mA	260 mA
	2x35		350 mA	330 mA
	2x49		480 mA	450 mA
	2x54		540 mA	500 mA
	2x58	T8	500 mA	460 mA

#### Harmonic distortion in the mains supply

type	wattage W	lamp type	THD at 230 V / 50 Hz
PC 2/14-35/49/54 T5 PRO-M Ip 220–240 V 50/60/0 Hz	2x14	T5	< 15 %
	2x21		< 15 %
	2x28		< 10 %
	2x35		< 10 %
	2x49		< 10 %
	2x54		< 10 %
	2x58	T8	< 10 %

#### Output voltage

type	U <sub>out</sub>
PC 2/14-35/49/54 T5 PRO-M Ip 220–240 V 50/60/0 Hz	300 V

#### Ballast lumen factor

##### EN 60929 8.1

type	wattage W	lamp type	AC/DC-BLF at U = 198–254 V, 25 °C
PC 2/14-35/49/54 T5 PRO-M Ip 220–240 V 50/60/0 Hz	2x14	T5	1.00
	2x21		1.00
	2x28		1.00
	2x35		1.00
	2x49		1.00
	2x54		1.00
	2x58	T8	1.00