

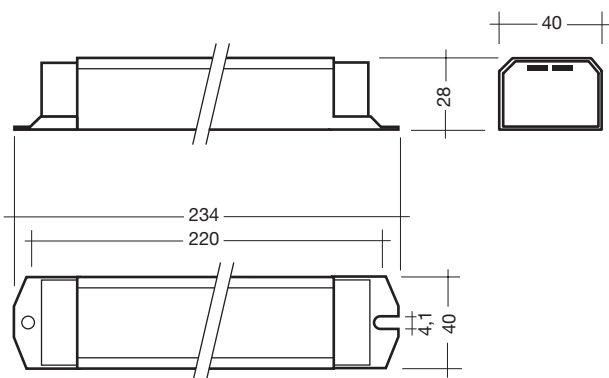

Electronic compact ballasts lamps TC-DEL, TC-TEL

PC TCT PRO sl 26/32 W 220–240 V 50/60/0 Hz



- Defined warm start < 1.5 s
- Constant light output independent of fluctuations in mains voltage
- Average service life = 50,000 h (at t_a max. with a failure rate ≤ 0.2 % per 1000 operating hours)
- AC operation 198–254 V
- DC operation 176–280 V, ignition must be ≥ 198 V
- Power factor > 0.96
- Overvoltage protection 320 V_{AC} for 1 hour
- overvoltage indication starting at input voltage 267–306 V_{AC}
- undervoltage protection (shut down) below 150 V_{AC} / 176 V_{DC}
- Operating frequency ≥ 40 kHz

- suitable for automatic and manual wiring with insulation displacement connector (IDC)
- wide operating temperature range from -25 °C to +55 °C
- suitable for use in emergency lighting installations in accordance with VDE 0108
- safe switch off of defective lamps
- automatic re-start after lamp change
- for luminaires with ∇ or ∇ and ∇ in acc. with EN 60598/VDE 0710 and VDE 0711
- suitable for luminaires with protection class SK I and SK II
- Ingress protection IP 20
- thermal protection according to EN 61347-2-3 C5e ∇

Approvals:

- EN 55015
- EN 55022
- EN 61347-2-4
- EN 60925
- EN 61347-2-3
- EN 60929
- EN 61000-3-2
- EN 61547
- acc. VDE 0108
- IEC 68-2-64 Fh
- IEC 68-2-29 Eb
- IEC 68-2-30

Lamp		Ballast													
wattage W	type	type	article number	length mm	fixing centres D mm	weight kg	lamp-power W	circuit power W ①	Celma-class EEI	current at 50 Hz 220V A	240V A	λ at 50 Hz 220V	240V	tc point °C	temperature range t_a °C
2x26	TC-DEL	PC 2/26/32 TCT PRO sl	22176115	234	220	0.28	48	53.5	A2	0.25	0.23	0.98	0.96	75	-25 → +55
2x26	TC-TEL	PC 2/26/32 TCT PRO sl	22176115	234	220	0.28	48	53.5	A2	0.25	0.23	0.98	0.96	75	-25 → +55
2x32	TC-TEL	PC 2/26/32 TCT PRO sl	22176115	234	220	0.28	64	68.9	A2	0.32	0.30	0.99	0.97	75	-25 → +55

① measured according to EN 50294

Lamp starting characteristics

Warm start
Starting time 1.5 secs with AC and DC operation
Cathode heating will be reduced after preheat time

AC operation

Mains voltage:
220–240 V 50/60 Hz
198–264 V 50/60 Hz including safety tolerance ($\pm 10\%$)
202–254 V 50/60 Hz including performance tolerance (+6 % / -8 %)

DC operation

220–240 V 0 Hz
198–280 V 0 Hz certain lamp start
176–280 V 0 Hz operating range
Light output level in DC operation: 100 %

Emergency lighting

Use in emergency lighting installations according to VDE 0108 or for emergency luminaires according to EN 61347-2-3 appendix J.

Instant start after mains interruption < 0.5 s



Intelligent Voltage Guard

Intelligent Voltage Guard is the name of the new electronic monitor from TridonicAtco. This innovative feature of the PC PRO family of control gear from TridonicAtco immediately shows if the mains voltage rises above or falls below certain thresholds. Measures can then be taken quickly to prevent damage to the control gear.

- If the mains voltage rises above ≥ 306 V the lamps start flashing on and off.
- This signal "demands" disconnection of the power supply to the lighting system.
- If the mains voltage falls below 150 V the control gear automatically disconnects the lamp circuit to protect the control gear from being irreparably damaged.



Smart Heating

PC PRO ignition technology (smart heating) optimises lamp start and ensures no energy is wasted. After the lamp ignition the filament heating is reduced automatically to a defined minimum value. This reduction in filament heating, saves energy, yet maintains the proper operating conditions for the lamp. The lamp is always operated within specification.

Mains currents in DC operation

Type	wattage W	Mains current at $U_n = 220$ VDC	Mains current at $U_n = 240$ VDC
PC 2/26/32 TCT PRO sl 220-240 V 50/60/0 Hz	2x26	240 mA	220 mA
PC 2/26/32 TCT PRO sl 220-240 V 50/60/0 Hz	2x32	308 mA	280 mA

Harmonic distortion in the mains supply

Type	wattage W	THD at 230 V/50 Hz
PC 2/26/32 TCT PRO sl 220-240 V 50/60/0 Hz	2x26	< 10 %
PC 2/26/32 TCT PRO sl 220-240 V 50/60/0 Hz	2x32	< 10 %

Working voltage

Type	wattage W	U_{out}
PC 2/26/32 TCT PRO sl 220-240 V 50/60/0 Hz	2x26	300
PC 2/26/32 TCT PRO sl 220-240 V 50/60/0 Hz	2x32	300

Ballast lumen factor

EN 60929 8.1

Type	wattage W	AC/DC-BLF at $U = 198-254$ V, 25 °C
PC 2/26/32 TCT PRO sl 220-240 V 50/60/0 Hz	2x26	≥ 1
PC 2/26/32 TCT PRO sl 220-240 V 50/60/0 Hz	2x32	≥ 1

ASIC light management

ASIC (Application specific integrated circuit) is the very latest in lighting management design technology. The lamp friendly warm start is delivering maximum lamp life and enables high switching frequency applications.

Temperature range

-25 °C to +55 °C

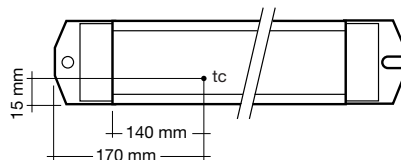

tc point is related to the ballast life time. PC PRO is designed for an average service life of 50,000 hours under reference conditions and with a failure probability of less than 10 %. This corresponds to an average failure rate of 0.2 % for every 1,000 hours of operation.

Verdrahtungshinweise

The lead length is dependant on the capacitance of the cable. For safety reasons, the PC PRO must only be earthed in the case of a safety class 1 luminaire. Earthing is not required for the device to operate. Connection to earth reduces radio interference.

Ballast	Terminal		Maximum capacitance allowed	
	Cold	Hot	Cold	Hot
PC 2/26/32 TCT PRO sl	11, 12, 13, 14	9, 10	200 pF	100 pF

With standard solid wire 0.5/0.75 mm² the capacitance of the lead is 30–80 pF/m. This value is influenced by the way the wiring is made.

Lamp connection should be made with symmetrical wiring.

Hot leads (9, 10) and cold leads (11, 12, 13, 14) should be separated as much as possible.

Loading of automatic circuit breakers

Automatic circuit breaker type	C10	C13	C16	C20	B10	B13	B16	B20
Installation \varnothing	1.5 mm ²	1.5 mm ²	2.5 mm ²	4.0 mm ²	1.5 mm ²	1.5 mm ²	2.5 mm ²	4.0 mm ²
PC 2/26/32 TCT PRO sl	22	30	38	48	11	15	19	24

Installation instructions

IDC interface

- solid wire with a cross section of 0.5 mm² according to the specification from WAGO

Horizontal interface

- solid wire with a cross section of 0.5–1.5 mm² according to the specification from WAGO
- strip 7.5–8.5 mm of insulation from the cables to ensure perfect operation of the screw terminals

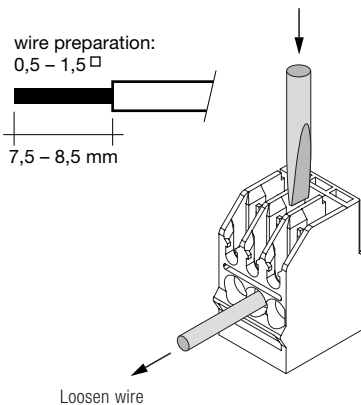

RFI

TridonicAtco ballasts are RFI protected in accordance with EN 55015 and EN 55022. To operate the luminaire correctly and to minimise RFI we recommend the following instructions:

- Connection to the lamps of the “hot leads” must be kept as short as possible (marked with *)
- Mains leads should be kept apart from lamp leads (ideally 5–10 cm distance)
- Do not run mains leads adjacent to the electronic ballast
- Twist the lamp leads
- Keep the distance of lamp leads from the metal work as large as possible
- Ballast must be earthed, either over the terminal or over the mounting screw of the ballast
- Mains wiring to be twisted when through wiring
- Keep the mains leads inside the luminaire as short as possible

Packaging

box of 10
63 carton/pallet
630 pieces/pallet

Defective lamp

If a lamp is defective, the ballast switches off and goes into standby. There is an automatic restart once the lamp has been changed.

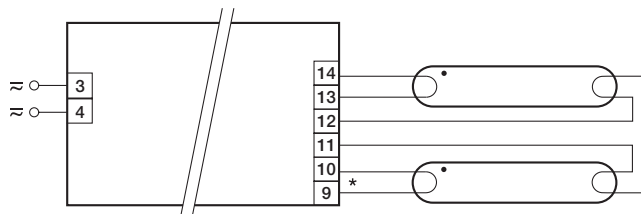

- * leads 9, 10 max. 1.0 m (< 100 pF)
- leads 11, 12, 13, 14 max. 2.0 m (< 200 pF)
- SK I - luminaires: earth of ballast housing required (according to IEC 598)
- SK II - luminaires: no earth required

Circuit diagramm PC 2x26/32 TCT PRO sl