

IP20     

TALEXconverter LCAI 80 W 700 mA one4all Ip
TALEXconverter IN-BUILT LCI

Product description

- Low-profile cross-section (21 x 30 mm)
- Plug-in terminals for simple connection
- 1-channel one4all constant current converter
- Dimming curve adapted to the sensitivity of the eye
- Noise-free precise control via DSI signal, switchDIM or DALI
- Powerless switching via a digital interface (no need for switching via mains)
- Fault reporting and programmable operating parameters in DALI mode
- 1 addressable output channel
- 700 mA PWM output signal
- Overload protection with automatic restart^①
- Short-circuit shutdown feature with automatic restart^①
- No-load shutdown feature with automatic restart^①
- Intelligent Temperature Guard (protection against thermal damage)^②
- Connecting cable, cable cross-section 0.5 – 1.5 mm²
- Power input on standby < 1 W
- switchDIM-MEMORY and corridorFUNCTION
- Type of protection IP20

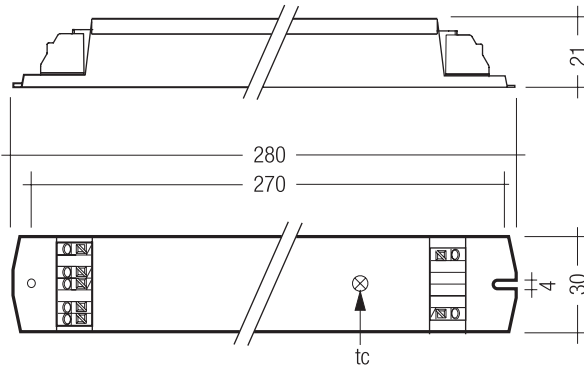

Technical data

Rated supply voltage	220 – 240 V
Rated current (at 230 V 50 Hz)	410 mA
Input voltage, AC	198 – 264 V
Mains frequency ^③	50 / 60 Hz
Typ. efficiency (at 230 V / 50 Hz)	92 %
λ (at 230 V / 50 Hz)	0.95
THD (applying to the current)	< 20 %
Inrush current	40 A
Control input dimming	DSI, DALI, switchDIM
Stand-by power at 230 V	< 1 W
Output voltage range	50 – 120 V
Max. output voltage ^④	420 V
Output current tolerance	± 5 %
Output current	700 mA
Output power	80 W
Dimming range	3 – 100 %
PWM frequency	400 Hz
Set up time at 230 V (acc. to the DALI standard)	600 ms
Hold time at power failure	> 20 ms
t_a operating (at lifetime 50,000 h)	-25 ... +45 °C
Max. casing temperature t_c	75 °C
Storage temperature	-20 ... +60 °C
Weight	0.220 kg
Dimensions LxWxH	280 x 30 x 21 mm
Hole spacing D	268 mm

^① The device switches off at short-circuit, in no-load (too low output voltage) and in overload (too high output voltage). The converter tries to restart every 7 s until the failure is fixed.

^② At an over temperature the output power will be reduced up to 70 %.

^③ The device is not suitable for DC operation.

^④ No-load operation

Ordering data

Type	Article number
LCAI 0080/0700 I010 one4all 220-240 V	86459191

Packaging: 25 pieces/carton, 700 pieces/pallet

Standards

- EN 55015
- EN 61000-3-2
- EN 61000-3-3
- EN 61347-1
- EN 61347-2-13
- EN 61547
- EN 62384
- IEC 62386-101
- IEC 62386-102
- IEC 62386-207 (DALI DEVICE Type 6)

Notes



- Not qualified for uses with protection class 3
- For further information on installation please refer to the brochure entitled „Requirements for Installation of Non-SELV LED converters“.

Control input (DA/D1, DA/D2)

Digital DALI/DSI signal or switchDIM can be wired on the same terminals (DA/D1 and DA/D2).

Digital signal DALI/DSI

The control input is non-polar and protected against accidental connection with a mains voltage up to 264 V. The control signal is not SELV. Control cable has to be installed in accordance to the requirements of low voltage installations. Different functions depending on each module.

switchDIM

Integrated switchDIM function allows a direct connection of a push to make switch for dimming and switching.

Brief push (< 0.6 s) switches converter ON and OFF. The converters switch-ON at light level set at switch-OFF.

When the push to make switch is held, LED modules are dimmed. After repush the LED modules are dimmed in the opposite direction.

In installations with converters with different dimming levels or opposite dimming directions (e.g. after a system extension), all converters can be synchronized to 50 % dimming level by a 10 s push.

Use of push to make switch with indicator lamp is not permitted.

corridorFUNCTION

The corridorFUNCTION can be programmed in two different ways.

To program the corridorFUNCTION by means of software a DALI-USB interface is needed in combination with a DALI PS. The software can be the masterCONFIGURATOR, the pcaCONFIGURATOR or the corridorFUNCTION CONFIGURATOR.

To activate the corridorFUNCTION without using software a voltage of 230V simply has to be applied for five minutes at the switchDIM connection.

The unit will then switch automatically to the corridorFUNCTION.

Note:

If the corridorFUNCTION is wrongly activated in a switchDIM system (for example a switch is used instead of pushbutton), there is the option of installing a pushbutton and deactivating the corridorFUNCTION mode by five short pushes of the button within three seconds.

Dimming

Dimming range 3 % to 100 %

Digital control with:

- DSI signal: 8 bit Manchester Code
Speed 3 % to 100 % in 1.4 s
 - DALI signal: 16 bit Manchester Code
Speed 3 % to 100 % in 0.5 s
- Programmable parameter:
 Minimum dimming level
 Maximum dimming level
 Default minimum = 3 %
 Programmable range $3\% \leq \text{MIN} \leq 49\%$
 Default maximum = 100 %
 Programmable range $100\% \geq \text{MAX} \geq 50\%$

Dimming curve is adapted to the eye sensitiveness.

Dimming characteristics

Digital dimming value

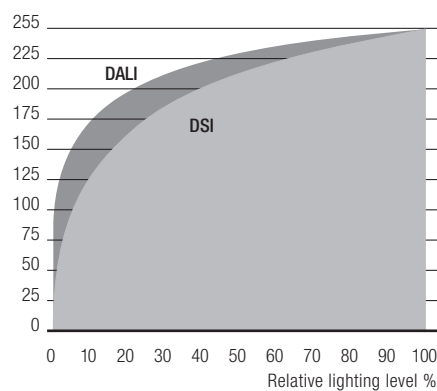

Dimming characteristics as seen by the human eye. A linear dimming characteristic can be activated optionally via DALI.

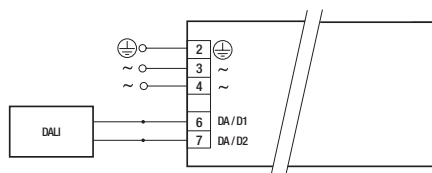

DALI TALEXconverter LCAI 0080/0700 I010 one4all

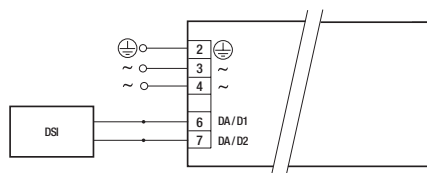

DSI TALEXconverter LCAI 0080/0700 I010 one4all

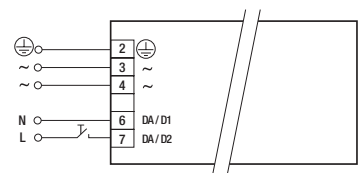

switchDIM TALEXconverter LCAI 0080/0700 I010 one4all

Maximum loading of automatic circuit breakers

Automatic circuit breaker type	C10	C13	C16	C20	B10	B13	B16	B20
Installation Ø	1.5 mm ²	1.5 mm ²	2.5 mm ²	4.0 mm ²	1.5 mm ²	1.5 mm ²	1.5 mm ²	2.5 mm ²
LCAI 0080/0700 I010 one4all	14	18	22	26	7	9	11	13

Wiring guidelines

- The cables should be run separately from the mains connections and mains cables to ensure good EMC conditions
- The maximum secondary cable length at the terminals is 5 m. The LED wiring should be kept as short as possible to ensure good EMC
- The LED modules must be operated in series on constant current converter TALEXconverter LCAI 0080/0700 I010 one4all
- The converter does not have polarity reversal protection on the secondary side. LED modules that do not have polarity reversal protection may be damaged if polarity is reversed.
- Converter is not SELV (output voltage up to 420 V). See EN 60598-1

Release of the wiring

Press down the “push button” and remove the cable from front.

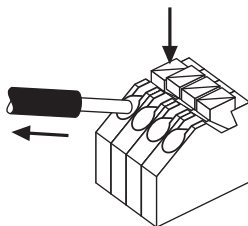

Wiring type and cross section

The wiring can be in flexible cable with ferules or solid. For perfect function of the push-wire terminals the strip length should be 8.5–9.5 mm. Please use only one wire per terminal.

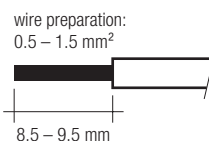

Circuit diagrams

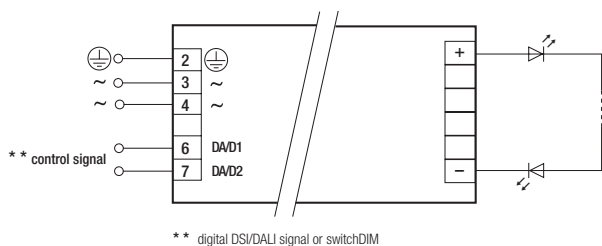

LED's have to be connected as shown above to work properly. It is possible to connect a different number of LED's on two circuits. The minimum power load has to be connected. Otherwise the converter will switch off.

 Information about the correct handling of LEDs can be found in the TALEX brochure “Installation instructions and guidelines” → www.tridonic.com