

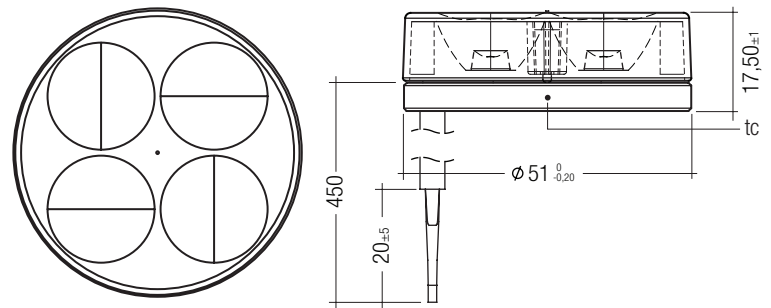

TALEXengine FULMEN 25° TALEXengine FULMEN

Product description

- LED light engine for spotlights
- Narrow beam angle (25°)
- Compact dimensions
- High luminous intensity
- Available in different light colours
- Dimming range 0.1 to 100 %
- NTC for temperature control
- Linear lenses made of PMMA
- Mounting plate made of aluminium
- Attached with M3 screws
- Designed for SELV converters
- Connection: Cable 450 mm
- Cooling required



Technical data

Beam characteristic	25°
Ambient temperature t_a	-20 ... +55 °C
Typ. t_c point	65 °C
Weight	95 g
Protection class	III
Risk group (EN 62471:2008)	0



Standards, page 2

Colour temperatures and tolerances, page 4

Ordering data

Colour temperature	Colour	Type	Article number
3,000 K	Warm white	LED FULMEN-2 D51 3000K 500MA 27W 25°	89601400
4,000 K	Neutral white	LED FULMEN-2 D51 4000K 500MA 27W 25°	89601401

Packaging: 12 pieces

Specific technical data

Type	Typ. luminous flux ^①	Number of channels	Current per channel ^②	Typ. supply voltage	Power consumption	Colour rendering index CRI	Efficacy module	Efficacy system ^③
LED FULMEN-2 D51 3000K 500MA 27W 25°	1,500 lm	2	500 mA	27 V	27 W	80	56 lm/W	50 lm/W
LED FULMEN-2 D51 4000K 500MA 27W 25°	1,800 lm	2	500 mA	27 V	27 W	80	67 lm/W	60 lm/W

All values at $t_a = 25$ °C and $t_c = 65$ °C.

^① Tolerance range for optical and electrical data: ± 10 %.

^② Exceeding the max. operating current leads to an overload on the TALEXengine. This may in turn result in a significant reduction in lifetime or even destruction of the TALEXengine.

^③ With mentioned converters in the converter matrix.

Converter matrix – TALEXengine FULMEN 25°

IN-BUILT LCI		
Type	0030 K500 one4all	
Art. no.	86458561	
Assignable converter		
Type	Min.	Max.
TALEXengine FULMEN 25°	1	1

Standards

- EN 62031
- EN 62471

Thermal design and heat sink

The rated life of TALEX products depends to a large extent on the temperature. If the permissible temperature limits are exceeded, the life of the TALEXengine module will be greatly reduced or the TALEXengine module may be destroyed.

Therefore the TALEXengine FULMEN 25° needs to be mounted onto a heat sink.

Tridonic's excellent thermal design for the TALEXengine products provides the lowest thermal resistance and therefore allowing new compact designs without sacrificing quality, safety and life time.

Mounting instruction



TALEXengine modules from Tridonic which have to be installed on a heat sink have to be connected with heat-conducting paste or heat conducting adhesive film and fixed with M3 screws.

The fixing/cooling surface must be cleaned before installing the TALEX modules to remove all dirt, dust and grease.

None of the components of the TALEXengine module (substrate, LED, electronic components etc.) may be exposed to tensile or compressive stresses.

For further information please refer to to the brochure entitled "TALEX installation instructions and guidelines".

Temperature control

An NTC resistor is on the board of the TALEXengine FULMEN 25° to control the tc temperature during the operation.

Exact position see drawing on page 1.

The details of the 22 kΩ NTC (order number B57431V2223J062) you can find in the data sheet of the manufacturer AVX (Nr. NB12Q00224).

Characteristic line of NTC

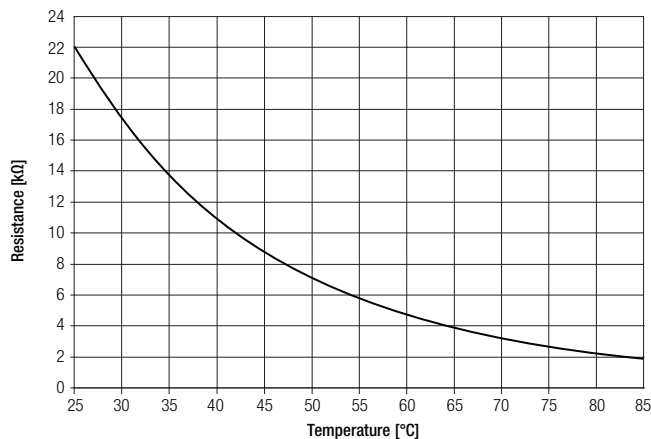

Lifetime

tc temperature in °C	luminous flux in %	lifetime in h
25	80	60,000
	70	81,000
	50	132,000
45	80	44,000
	70	64,000
	50	110,000
65	80	32,000
	70	50,000
	50	91,000
75	80	25,000
	70	41,000
	50	81,000

Cooling characteristics

Operation with 1.000 mA (500 mA per channel)

TALEXengine FULMEN 25°

ta	tc	Rth, hs-a
25°C	65°C	1.3 K/W
35°C	65°C	0.8 K/W
45°C	65°C	0.4 K/W

Notes

Rth = thermal resistance of heat sink.

A thermal connection between TALEXengine FULMEN and heat sink with heat-conducting paste or heat conducting adhesive film is necessary.

Thermal behaviour

storage temperature	-20–80 °C
operating temperature	-20–55 °C
tc max.	70 °C

Characteristic line of relative luminous flux

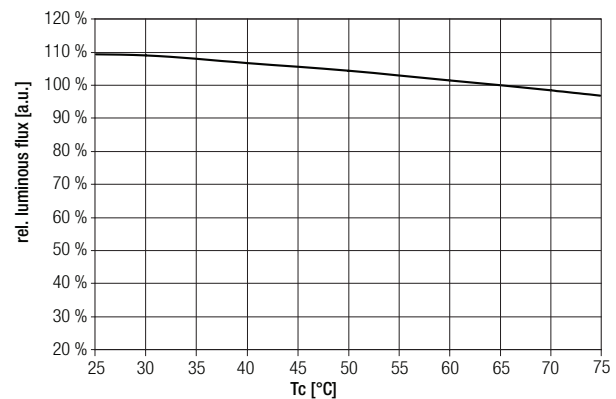

Wiring

Cable: LAPP UNITRONIC LIHH 6x0,14; length: 450 mm

Number	PIN 1	PIN 2	PIN 3	PIN 4	PIN 5	PIN 6
Colour	white	brown	green	yellow	grey	pink
Function	channel 1 +	channel 1 -	channel 2 +	channel 2 -	NTC	NTC

Wiring example

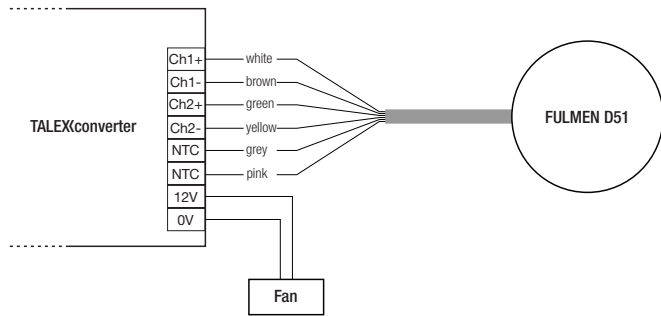

Mounting

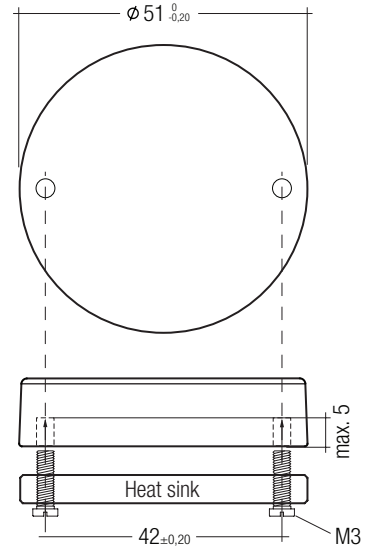

Optical characteristics TALEXengine FULMEN 25°

The optical design of the TALEXengine product line ensures optimum homogeneity for the light distribution.

Light distribution

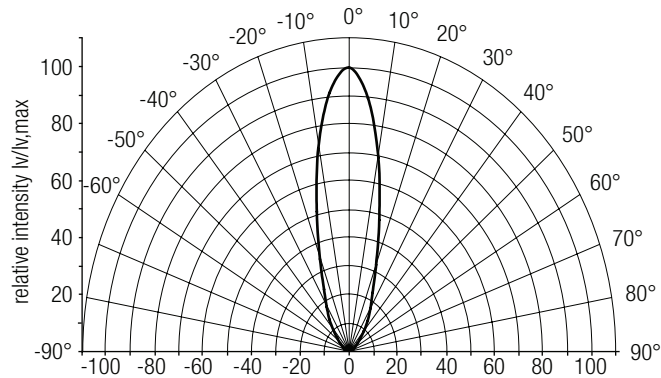

Light colour	$I_{v,max}$
3,000K	3,500 cd
4,000K	4,500 cd

Coordinates and tolerances according to CIE 1931

The specified colour coordinates are measured by a current impulse of 500 mA and a duration of 100 ms.
The ambient temperature of the measurement is $t_a = 25\text{ °C}$.
The measurement tolerance of the colour coordinates are ± 0.01 .

3,000 K

	x0	y0
Centre	0,4460	0,3990

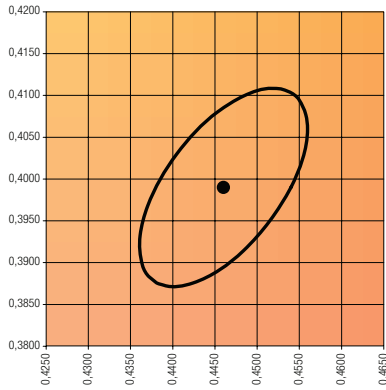

Characteristic line 3,000 K

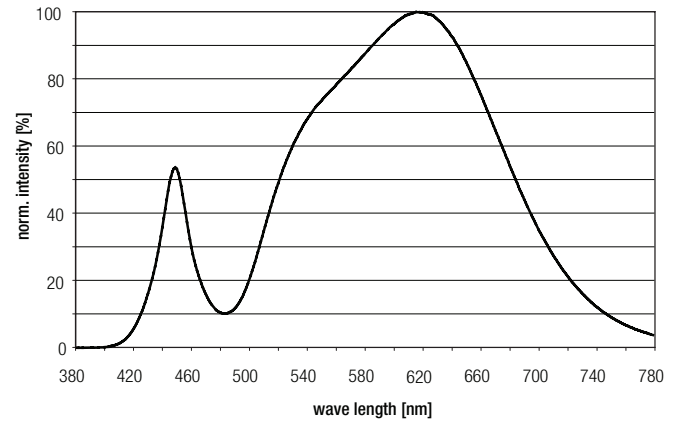

4,000 K

	x0	y0
Centre	0,3860	0,3780

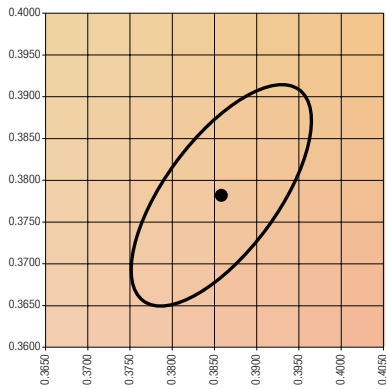

Characteristic line 4,000 K

