

DALI SCI2

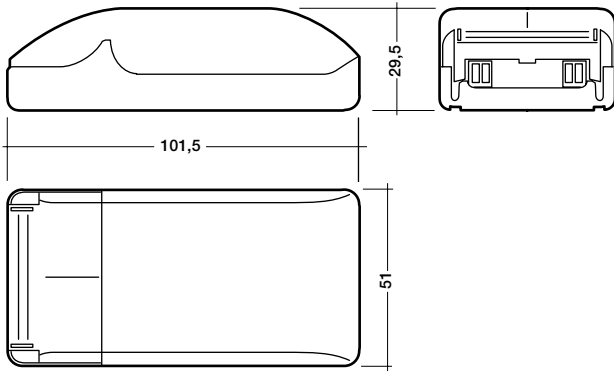

**Function:**

- The DALI SCI2 interface module enables DALI installations to be connected to personal computers or programmable controllers in DALI installations.
- This means that complex DALI installations can be easily addressed, programmed and operated.
- DALI SCI2 is an extension of DALI SCI and also supports monitoring of the DALI bus, which means that activity on the bus can be logged.
- DALI SCI2 supports standard and TridonicAtco-specific DALI commands.

**Installation:**

- DALI SCI2 is supplied directly via the DALI line and from the serial RS 232 interface and need not be connected to the mains power supply.
- DALI is not SELV. The installation instructions for low voltage therefore apply.
- DALI SCI is an opto-isolated connection between the DALI signal line and the serial RS 232 interface.

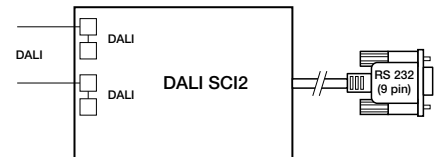

Connection diagram

Type		DALI SCI2
Article number		24166096
Power supply	-	From the DALI line and RS 232
Input current	-	6 mA (DALI line)
Input	1	RS 232 (personal computer)
Input	Cable length	approx. 0.8 m
Output	1	DALI
Temperature	Permissible ambient temperature	0 °C → 50 °C

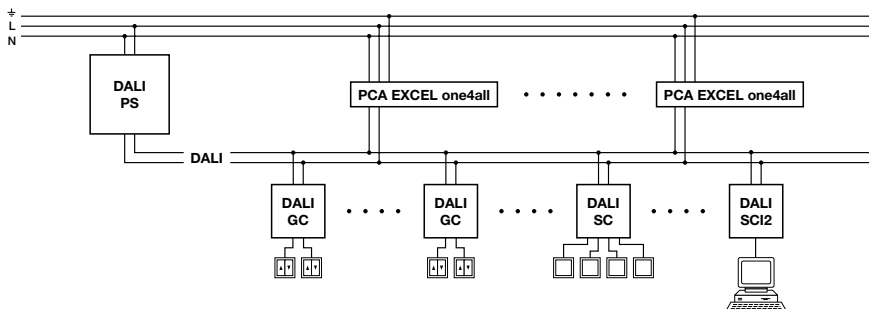

## Interface description:

### Connection:

The SCI2 is supplied from the DALI bus AND (because of electrical isolation) from the serial Port of the PC. For this purpose the RS232 signals RTS and DTR must be set to the following levels before any communication can take place:

RTS = +6 ... +12 V

DTR = -6 ... -12 V

This could be done in software or by hardware wiring.

RS232 connector	
pin 5	Ground
pin 2	TxD
pin 3	RxD
pin 4	DTR (for supply purpose only)
pin 7	RTS (for supply purpose only)

### Serial Interface Configuration:

38400 baud; 8 data bit; no parity; 1 stop bit (38400, 8, n, 1)  
half duplex

### Transmission Protocol:

To communicate with the DALI SCI2 the following simple transmission protocol is used. The forward and backward frame both consist of 5 bytes. Send this frame to the DALI SCI2:

8 bit	8 bit	8 bit	8 bit	8 bit
<b>Control</b>	<b>DATA HIGH</b>	<b>DATA MID</b>	<b>DATA LOW</b>	<b>Check Sum</b>

The DALI SCI2 will answer with:

8 bit	8 bit	8 bit	8 bit	8 bit
<b>Status</b>	<b>DATA HIGH</b>	<b>DATA MID</b>	<b>DATA LOW</b>	<b>Check Sum</b>

### Control:

bit 7	bit 6	bit 5	bit 4	bit 3	bit 2	bit 1	bit 0
ME	Identify/ nDALI	Echo	DSI/nDALI	0	0	0	0

bit 7: Monitor Enable. 1 = enable monitor function. If enabled the SCI2 sends all received DALI data back to the PC.

bit 6: High: no data is sent out on the DALI bus, answer to PC only (used to test connection)  
when DATA\_HI = , then Enable = DATA\_LO bit 0 (default: enable)

Low: DALI (DSI) output on the DALI bus

bit 5: High: immediate reply to PC (not waiting for DALI answer)

Low: waiting for DALI answer (10 ms max.) DALI „NO“ after 10 ms

bit 4: not used, should be set LOW for compatibility with future releases

bit 3: not used, should be set LOW for compatibility with future releases

bit 2..0: Mode Selection:

0, 1: not used

2: send DALI answer (8 bit data) (DATA\_LO)

3: send DALI (16 Bit) (DATA\_MID, DATA\_LO)

4: send eDALI (25 bit data) (DATA\_HI, DATA\_MID, DATA\_LO)

5: send DSI (8 bit data if DATA\_MID = 0, else 16 bit data (DATA\_MID, DATA\_LO))

## DATA HIGH, DATA LOW

If sent to the SCI2: DALI/DSI data. See description of the Control byte  
If received from the SCI2: see below.

### Status:

bit 7	bit 6	bit 5	bit 4	bit 3	bit 2	bit 1	bit 0
Identifier				Release	Status		

Identifier	DALI SCI2 ID = 6				
Release	0	(firmware release March 2002)			Status byte in current release
Status	000	OK			0x60
	001	DALI answer "NO"			0x61
	010	DALI 8 bit data		DATA = 8 bit DALI	0x62
	011	DALI 16 bit data		DATA = 16 bit DALI	0x63
	100	DALI 24 bit data		DATA = 24 bit DATA	0x64
	101	DSI Data (8 bit if DATA_MID = 0, else 16 bit ext. DSI)			0x65
	110	not used			0x66
	111	Error	Check sum:	DATA = 1	0x67
			DALI-bus short circuit:	DATA = 2	
			DALI recive error:	DATA = 3	

### Check sum

XOR-combination of the previous 4 bytes (Control/Status ... to ... DATA\_LO).

### Attention:

The DALI SCI2's reply should be checked under all circumstances. This assures the DALI command has been sent (and received) and the SCI2 is ready to handle a new command. There is no command buffer in the SCI2!

DALI SCI2 complies with the DALI standard; the specification with the DALI commands can be found in IEC 60929 (in future in IEC 62386). This can be obtained from the local standards office.

The function of DALI SCI2 has been tested with all TridonicAtco DALI products, and the function guarantee applies only to these products.