

SMART LS II / SMART LS II Ip

Maintained illuminance

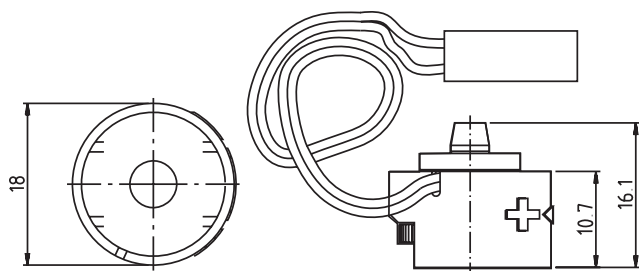

Function:

In combination with the PCA EXCEL and PCA ECO control gear, both the SMART-LS sensor and the SMART-LS II Ip sensor offer a cost effective and easy to install maintained illuminance system. They register the available ambient light and maintain a pre-defined light level. Through the use of daylight it is possible to obtain savings of up to 30 % on energy, in addition to those associated with an electronic high-frequency control gear.

Changes in daylight will be automatically adjusted by the SMART-LS sensor and SMART-LS II Ip sensor, thereby ensuring constant illuminance. Setting the SMART-LS sensor and SMART-LS II Ip sensor is simplicity itself as no special tools or accessories are required.

Once the SMART-LS sensor and SMART-LS II Ip sensor have been installed the PCA EXCEL/PCA ECO control gear can be switched ON/OFF by interrupting the mains or via the DSI signal. It is possible to adjust the light level of the control

gear and create a temporary override situation through the use of switchDIM. However, it is not possible to override the SMART-LS sensor and SMART-LS II Ip sensor through the DSI signal other than to switch the control gear.

The SMART-LS sensor and SMART-LS II Ip sensor ambient light sensor allows up to 50 DSI devices to be controlled when combined with a DSI-A/D.

DSI-A/D article number: 86453957

Type	article number	no. of control gear PCA EXCEL/ECO	max. lead length cm	suitable for
SMART LS II	86448347	1	50	T8, TC-L, compact devices
SMART LS II Ip	86458258	1	50	T5 Ip

System with spot measurement

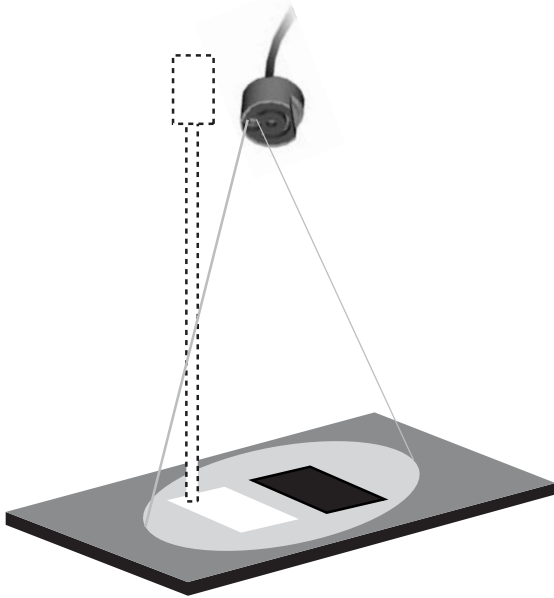

SMART LS II / SMART LS II Ip detection zone

The sensor detection zone is dimensioned so that the entire work area is covered and evaluated, not just a single point. This ensures that false readings are not made as a result of moving objects across the work surface such as white paper, which would otherwise lead to a sudden change in the brightness level.

The constant light value is set by adjusting the thumbwheel on the sensor. No tools are needed. Turn the wheel to the right for lower light settings, and to the left for higher settings. The maximum angle is 270°. The absolute value depends on the luminaire used and the reflectance in the room. The rate at which the dimming value is changed is dynamically linked to the overall lighting level.

Dimming speed

Change from 1 % to 100 %: 17 sec.
Change from 100 % to 1 %: 34 sec.

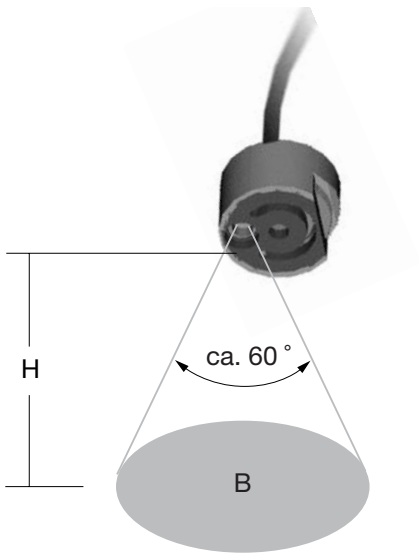

Detection zone

Installed height H m	Area covered B Ø m
1.6	1.8
1.8	2.1
2.0	2.3
2.2	2.5
2.4	2.8
2.6	3.0
2.8	3.3
3.0	3.5



e.g. 2x58 W luminaire
reflective index approx. 30 %
working surface 80 cm high
ceiling height 250 cm

setting	luminous (lux)
maximum (+)	840
middle	500
minimum (-)	200

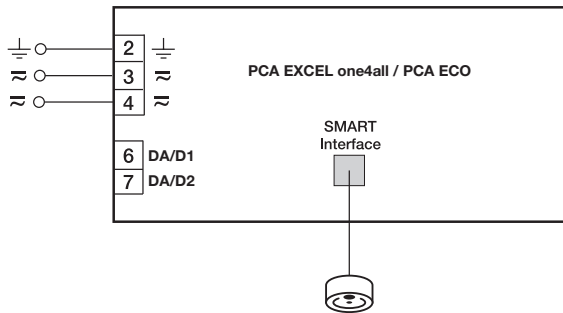

SMART LS II / SMART LS II Ip

Switch ON/OFF via mains voltage. Soft start of PCA EXCEL/PCA ECO, this is followed by automatic adjustment to the constant light value selected on the sensor.

Type	article number	no. of control gear PCA EXCEL/ECO	max. lead length cm	suitable for
SMART LS II	86448347	1	50	T8, TC-L, compact devices
SMART LS II Ip	86458258	1	50	T5 Ip

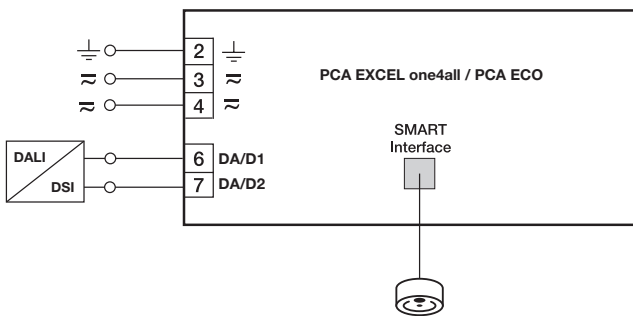

SMART LS II / SMART LS II Ip and DSI/DALI

DSI:

Switch ON/OFF via digital DSI signal. DSI signal = 0 zero-power switch OFF, DSI signals ≥ 1 switch ON. ON means regulating to the value set on the sensor.

DALI:

Switch ON/OFF via digital DALI signal. DALI signal = 0 zero-power switch OFF, DALI signals ≥ 1 switch ON. ON means regulating to the value set on the sensor. The brightness value may be changed temporarily by indirect DALI dimming commands (UP/DOWN, STEP-UP/ STEP-DOWN,...). With PCA EXCEL Ip it is also possible to recall stored DALI scenes. Constant lighting control is deactivated and the stored scene value is called up.

Type	article number	no. of control gear PCA EXCEL/ECO	max. lead length cm	suitable for
SMART LS II	86448347	1	50	T8, TC-L, compact devices
SMART LS II Ip	86458258	1	50	T5 Ip

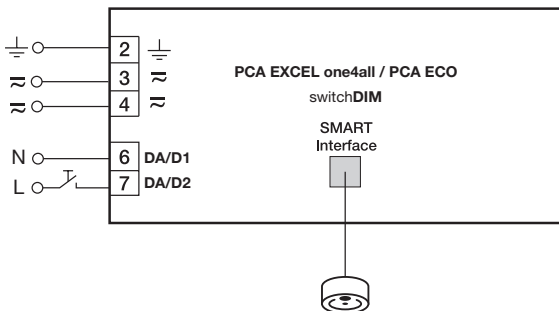

SMART LS II / SMART LS II Ip and switchDIM

PCA EXCEL and PCA ECO with switchDIM function and SMART LS or SMART LS II Ip can be switched ON/OFF by a brief key press. A long key press dims UP/DOWN and shifts the set value to which the SMART LS or SMART LS II Ip constantly controls. After ON/OFF, the original value previously set on the SMART LS or SMART LS II Ip is active again.

Type	article number	no. of control gear PCA EXCEL/ECO	max. lead length cm	suitable for
SMART LS II	86448347	1	50	T8, TC-L, compact devices
SMART LS II Ip	86458258	1	50	T5 Ip

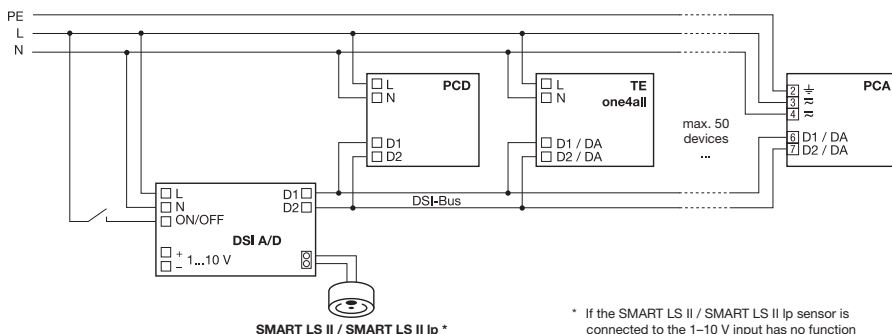

SMART LS II / SMART LS II Ip and DSI-A/D

If SMART LS II / SMART LS II Ip is used in combination with a DSI-A/D up to 50 DSI units can be controlled as a function of the ambient light.

**Light sensor for PCA ECO/PCA EXCEL one4all
For building into luminaires**

Installation:

SMART LS II / SMART LS II Ip is connected directly to the SMART interface in the PCA EXCEL one4all/PCA ECO ballast. One sensor controls one ballast. Installation must be in accordance with the low voltage directive. The control gear must be disconnected from the power supply during installation. The sensor is automatically detected after a mains reset.

To avoid false readings, the sensor should be installed so there is no direct light from the lamp in the detection zone.

The sensor can be fixed to the lamp by means of the clip provided.

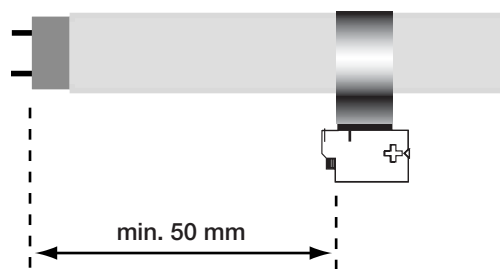
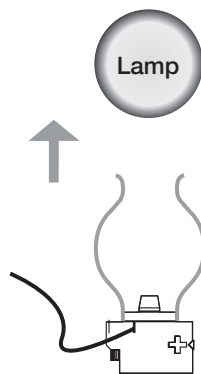

① For further technical information please visit www.tridonicatco.com