

Digital pulse ignitor with automatic shutdown
High pressure sodium lamps and metal halide lamps

powerPULSE

ZRM 4000 / ZRM 4000/400

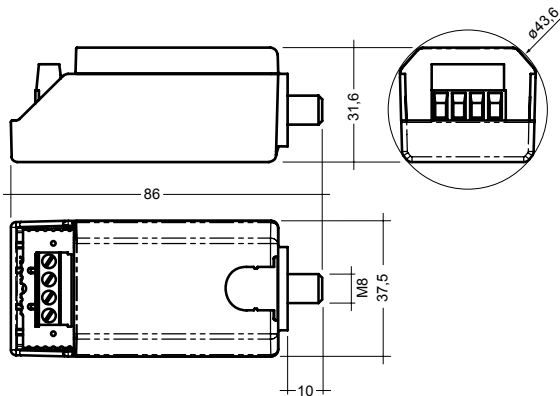

- Innovative digital safety ignitor
- Pulse/pause ignition principle for:
 - shorter restart times (up to 30 %)
 - minimum downtime in ignition mode (up to 90 %)
- No annoying flashing due to three-start-counter and switch-off when lamp is defect
- Silent operation
- Low weight
- Regulated maximum ignition voltage and therefore enhanced safety for the control gear
- Also suitable for special HS lamps (Plus, Super, XL)
- Casing: two-part
- Screw terminals for 2.5 mm²
- Small number of types
- Not potted – environmentally friendly design

Type		ZRM 4000 powerPULSE	ZRM 4000/400 powerPULSE
article number		86458458	86458459
rated voltage	V	220–240	380–440
permitted input voltage	V	198–264	342–484
mains frequency	Hz	50/60	50/60
ignition voltage	V	4100	4100
wattage HS	W	70*–1000	600–750
wattage HI	W	35–1800	1800–2000
consumption at 240 V mains voltage	W	0.90	–
consumption at 400 V mains voltage	W	–	1.50
pulse width at 90 % ignition voltage	µs	> 10 µs	> 10 µs
number of pulses per halfwave		1	1
phase displacement of ignition pulses	°el	72 252	72 252
switch-on voltage	V	> 198	> 342
switch-off voltage		digital	digital
maximum load capacitance	pF	4000	4000
minimum distance from lamp	m	< 0.1	< 0.1
maximum distance from lamp	m	see table overleaf	see table overleaf
maximum operating temperature ta	°C	+80	+80
minimum operating temperature ta	°C	-30	-30
maximum housing temperature tc	°C	+85	+85
weight	g	52	58

* only HS lamps for $U_{\text{ign}} > 2.8 \text{ kV}$

Installation instructions

Wiring type and cross section

Stranded wire or solid wire with a cross section between 0.5 and 2.5 mm² may be used for wiring. Strip 7 mm of insulation from the cables to ensure perfect operation of the screw terminals. The lamp cable is to be adapted according to the ignition voltage.

wire preparation:
0.5–2.5 □

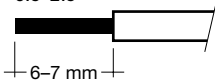

When using multiple wires in one clamp cage it is recommended to use the same wire types (solid or flexible) and same wire diameters. Above all, it must be made sure that the wires are fastened securely

Important advice

Always switch off at the mains before changing the lamp. Warning – starting voltage up to 4.3 kV!

Not suitable for use with lamps with internal ignitors.

Wiring notes

The ignitor can be used in luminaires for Protection Class 1 and Protection Class 2. The maximum allowable torque on the M8 nut is 4 Nm. The maximum allowable pressure on the terminal-screw may not surpass 100N in installed condition (refer to drawing).

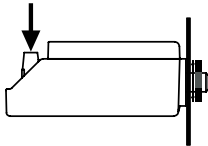

ATTENTION!

Terminals which weren't fastened sufficiently can cause charrings (maximum torque of terminal screws is 0,5 Nm). Wrong wiring can cause the destruction of the ballast.

Control gear

Control gear with pulse tapping is needed for operating the ZRM powerPULSE. For the product range see "Magnetic control gear with pulse tapping for pulse ignitors" in the TridonicAtco catalogue.

Packaging

50 pieces/box
24 box/pallet
1200 pieces/pallet

Certified

EN 61347-2-1
EN 60927
CE marked
ENEC approval

Safety shutdown

At the end of their useful life, lamps often cycle on/off. The powerPULSE ignitor recognises this condition and switches off the lamp after three complete on/off cycles unless the supply has been disconnected. Complete lamp shutdown enables a defective lamp to be easily identified. After the faulty lamp has been changed and the mains supply has been reset the ballast will start the lamp. If there is no lamp in the circuit or if a defective lamp is connected to the ballast, the ballast will switch off after approx. 20 minutes.

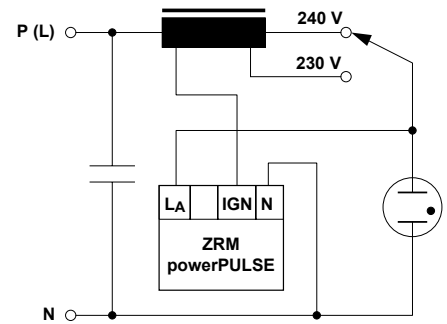

Circuit diagram ZRM powerPULSE

Auto reset function

After 60 minutes of fault-free operation the counter is automatically reset to zero. Another three starting attempts are possible.

Regulated ignition voltage

Irrespective of the rated voltage (198-264 V or 342-484 V for 400 V version) and cable length (see table below) the maximum ignition voltage of 4.3 kV is not exceeded.

Cable lengths

cable capacity	ZRM 4000 powerPULSE		ZRM 4000/400 powerPULSE	
	100 pF/m	200 pF/m	100 pF/m	200 pF/m
HI 35 W	>60 m	>30 m	–	–
70 W	50 m	25 m	–	–
100 W	55 m	27,5 m	–	–
150 W	45 m	22,5 m	–	–
250 W	45 m	22,5 m	–	–
400 W	40 m	20 m	–	–
1000 W	30 m	15 m	–	–
2000 W	–	–	45 m	22,5 m
HS 35 W	–	–	–	–
50 W	–	–	–	–
70 W	40 m	20 m	–	–
100 W	55 m	27,5 m	–	–
150 W	45 m	22,5 m	–	–
250 W	45 m	22,5 m	–	–
400 W	40 m	20 m	–	–
600 W	40 m	20 m	40 m	20 m
750 W	–	–	40 m	20 m
1000 W	30 m	15 m	–	–

Above maximum capacities are only attained with mains-parallel luminaire compensation. In inductive operation the maximum cable length is limited to about 2 m.

Long distances between ignitor and lamp

