

EM BASIC 230–240 V 50/60 Hz

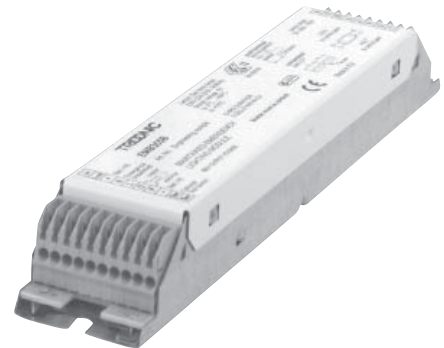
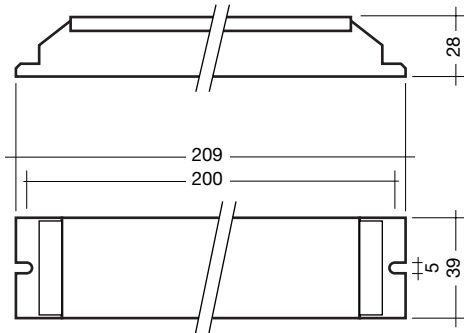

**Description:**

Emergency lighting modules with 1 hour or 3 hour duration. Five pole technology = 4 pole changeover and a delayed action relay for switching the mains supply to ensure compatibility with all electronic ballasts.

Versions fitted with a Test Switch allow emergency operation of the single emergency luminaire to be tested by operating the push button test switch.

High temperature Nickel Cadmium batteries.

**Features:**

**Module**

- Delayed action relay for mains supply to ensure compatibility with all electronic ballasts
- 1 hour or 3 hour duration
- AC output optimised for TC-DD and TC-L lamps
- DC output optimised for T8 lamps
- Cathode heating optimised for compact lamps
- Small size (28 mm x 39 mm cross-section)
- Change-over relay with high current contacts
- Suitable for fixed output and dimmable electronic ballasts
- Can be used with conventional wirewound ballasts
- IDC terminations
- Deep discharge protection
- Reverse battery polarity protected
- Complies with EN 61347-2-7 and EN 60925
- Complies with relevant clauses of EN 60598-2-22 and EN 50172
- Complies with EN 55015: 2006 + A1: 2007
- ENEC and BSI approved
- CE marked

**Batteries**

- High temperature NiCd cells
- Spade terminals for simple connection
- Connection can be made with end cap in place

**Packing quantities:**

EM BASIC:  
25 pieces/carton  
30 cartons/pallet  
750 pieces/pallet

Test Switch:  
25 pieces/bag  
200 pieces/carton

LED green:  
25 pieces/bag  
200 pieces/carton

Accu NiCd:  
25 pieces/carton

**EM BASIC 3 h – NiCd 4.0 Ah D cells**

type	article number	number of cells
EM 33A BASIC 230–240 V 50/60 Hz	89818556	3
EM 33B BASIC 230–240 V 50/60 Hz	89818655	3
EM 33C BASIC 230–240 V 50/60 Hz	89800000	3
EM 34A BASIC 230–240 V 50/60 Hz	89818557	4
EM 34B BASIC 230–240 V 50/60 Hz	89818662	4
EM 35A BASIC 230–240 V 50/60 Hz	89818581	5
EM 35B BASIC 230–240 V 50/60 Hz	89818667	5
EM 35C BASIC 230–240 V 50/60 Hz	89800001	5
EM 35D BASIC 230–240 V 50/60 Hz	89899621	5
EM 36A BASIC 230–240 V 50/60 Hz	89818654	6

**EM BASIC 1 h – NiCd 4.0 Ah D cells**

type	article number	number of cells
EM 13B BASIC 230–240 V 50/60 Hz	89895971	3
EM 13E BASIC 230–240 V 50/60 Hz	89899864	3
EM 14B BASIC 230–240 V 50/60 Hz	89899611	4

**Accu NiCd 4.0 Ah D cells**

type	article number	type of cells	number of cells
Accu NiCd 3A	89895960	stick	1x3
Accu NiCd 3B	89895976	side by side	3x1
Accu NiCd 4A	89895961	stick	1x4
Accu NiCd 4B	89895977	side by side	4x1
Accu NiCd 4C	89895978	stick + stick	2+2
Accu NiCd 5A	89895973	stick	1x5
Accu NiCd 5B	89895962	stick + stick	2+3
Accu NiCd 6A	89895963	stick + stick	3+3

type	article number	type	article number
LED EM green	89899605	Test switch EM 2	89805277

**Emergency lighting modules**  
**T5, T8, TC-DD, TC-L, TC-SEL, TC-DEL, TC-TEL linear and compact lamps**

**Technical data**

**Modules**

Rated mains supply voltage	230 – 240 V	Earth leakage current	< 0.5 mA
• with tolerances for performance (-10 %/+6 %)	207 – 254 V	Vibration test	IEC 60068-2-6 Fh
• with tolerances for safety (±10 %)	207 – 264 V	Bump test	IEC 60068-2-29 Eb
Mains frequency	50/60 Hz	Humidity	IEC 60068-2-30
Mains supply current	0.04 A		
Mains supply power	9 W	Flash Testing (no flashover or breakdown must occur):	Allows testing for compliance with EN 60598-1 to be carried out.
Recharge period	24 hours	High Voltage Insulation Resistance Testing (no flashover or breakdown must occur):	Up to 500 V DC between the phase and neutral conductors connected together and the earth.
Nominal charge current	210 mA		
Nominal discharge current (max. lamp power)			
• 3 h duration	1.1 A		
• 1 h duration	2.25 A		
Ambient temperature range	0 °C to +50 °C	<b>Batteries</b>	
Max. case temperature (measured on geometric centre of side)	+75 °C	Case temperature range (to ensure 4 years life)	0 °C to +55 °C
Mains change-over voltage	Complies with EN 60598-2-22	Storage life (in temperate conditions)	4 years
Ingress Protection	IP20	Battery voltage/cell	1.2 V
Safety Class	1	Capacity	4 Ah

**Ballast Lumen Factor (BLF) in %**

Duration	3 hours										1 hour		
	3 cells			4 cells		5 cells			6 cells	3 cells	3 cells	4 cells	
Battery	EM 33A BASIC	EM 33B BASIC	EM 33C BASIC	EM 34A BASIC	EM 34B BASIC	EM 35A BASIC	EM 35B BASIC	EM 35C BASIC	EM 35D BASIC	EM 36A BASIC	EM 13E BASIC	EM 13B BASIC	EM 14B BASIC
Lamp													
TC-DD	10 W	27		30		39				46			
	16 W	24		24		31				37			
	21 W			20		25				30			
	28 W			19		21				25			
	38 W					15				18			
	55 W									14			
T16	4 W	25		30		37				44			
	6 W	26		32		40				48			
	8 W	27		32		40				48			
	13 W	25		30		37				44			
	14 W	16		21		32							
	21 W			21* (2)		21* (2)							
	24 W					19							
28 W						14**							
T26	18 W	10			12	18	13					22	25
	30 W	9			13	18	14						
	36 W	8			10	16	10					16	19
	58 W				7	7	7				10		14
	70 W						7						
TC-L	18 W	18		18		19				22			
	24 W			17		20				24			
	34 W				9**	19				22			
	36 W				9**	20				24			
	40 W				8**		10**			8* (2)			
	55 W				5**		6**			6* (2)			
TC-SEL	5 W		20										
	7 W		14										
	9 W		11										
	11 W		16										
TC-DEL	10 W		13										
	13 W		16										
	18 W							12					
	26 W							15					
TC-TEL***	13 W		10										
	18 W							16					
	26 W							12					
	32 W							15					
	42 W								7				
								5					

\* (2) 2 hours only  
 \*\* Should only be used in maintained mode  
 \*\*\* Amalgam and non amalgam lamps

### EM BASIC Extended Application

The EM BASIC range consists of 4 different product types (A, B, C, D). These are needed due to the different starting and operating requirements of the various types of fluorescent lamps. Each EM BASIC type is optimised to give best possible lamp performance and life performance with the minimum number of battery cells.

Additional to this there is also the possibility to use only one type out of the EM BASIC range to operate most lamp types of a rated duration – the EM 34B BASIC for 3 hours and the EM 13E BASIC for 1 hour.

According to the statement above please note that by using only one EM BASIC type for the complete lamp range, some lamps will be run outside of the specification. This will lead to a decrease in the lamp performance.

In the following table an information about the effect on the duration and the BLF for all lamps which can be operated is listed.

### Ballast Lumen Factor (BLF) and duration

Lamp Type	EM 34B BASIC		EM 13E BASIC	
	Duration hours	BLF %	Duration hours	BLF %
T5	4 W	6	4,5	23
	6 W	6	3	23
	8 W	6	3	23
	13 W	4,5	2	22
	14 W	5,5	2	19
	21 W	3	1,5	18
	24 W	4,5	2	12
	28 W	3	1	15
	35 W	2,5	-	-
	39 W	3	1,5	9
	49 W	2,5	-	-
	54 W	3	1	8
	T8	18 W	6	2,5
36 W		3	1,5	9
58 W		3	1	10
TC-DEL	10 W	6	3	17
TC-D/TEL	13 W	6	2,5	16
	18 W	4,5	2,5	13
	26 W	4,5	2	11
TC-TEL	32 W	3	1,5	10
	42 W	3	1	9
TC-SEL	5 W	6	4,5	19
	7 W	6	3	19
	9 W	6	3	18
	11 W	5,5	2	22
TC-L	18 W	6	2,5	11,5
	24 W	4,5	2	11
	36 W	3	1,5	9
	40 W	3	1	9
	55 W	3	1	7
TC-DD	10 W	6	2,5	20
	16 W	4,5	2,5	15
	28 W	4,5	1,5	11
	38 W	4,5	1,5	8
T5 circline	40 W	3	1	9

## Emergency lighting modules

### T5, T8, TC-DD, TC-L, TC-SEL, TC-DEL, TC-TEL linear and compact lamps

#### Mechanical details:

Channel manufactured from 0.4 mm Galvalite galvanised steel.

Cover manufactured from 0.4 mm white precoated steel.

#### LED charge indicator

- Green
- Mounting hole 6.5 mm dia
- Length of LED lead 750 mm (Bezel supplied fitted to LED)

#### Test switch

- Mounting hole 7 mm dia
- Length of test switch lead 550 mm

#### Battery leads

- Quantity: 1 red and 1 black
- Length: 1000 mm (Accu NiCd 3B, 4B, 4C), 1300 mm (all others)
- Wire type: 0.5 mm<sup>2</sup> solid conductor
- Insulation temperature rating: 90 °C

#### Termination 1

Push on 4.8 mm receptacle to suit battery spade fitted with insulating cover

#### Termination 2

9 mm stripped insulation

Two-piece batteries are supplied with a 200 mm lead with 4.8 mm receptacles at each end and insulating covers to connect the separate sticks together.

#### CE marking:

The modules are CE marked for compliance with the low voltage directive.

Certificates of compliance are available to allow luminaires to be CE marked for compliance with the EMC directive.

#### Service life:

Average service life 50,000 hours under rated conditions with a failure rate less than 10 %. Average failure rate of 0.2 % per 1,000 operating hours

#### Batteries:

Connection method: 4.8 x 0.5 mm spade welded to end of cell

For the stick batteries this connection is accessible after the battery end caps have been fitted.

To inhibit inverter operation, only disconnect the batteries by removing the connector from the battery spade tags.

#### Electrical connections:

An earthed starting aid is recommended.

The module should be earthed by the fixings used to attach it to the luminaire.

#### Terminal block type:

Push wire and insulation displacement

#### Terminal block capacity

- Push wire: 0.5 to 1.5 mm<sup>2</sup> solid conductor
- Insulation displacement: 0.5 mm<sup>2</sup> solid conductor

Wire strip length: 7.5 to 8.5 mm

Lamp lead length: 2500 mm max.

The longer pair of leads should always be connected to terminals 3 and 8.

#### Batteries (stick):

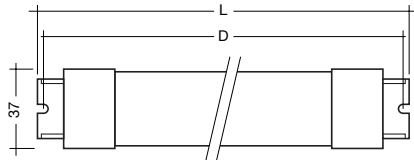

Type	length	fixing centres		weight (gms)
	L (mm)	D (mm)		
Accu NiCd 3A	218	201		400
Accu NiCd 4A	275	263		530
Accu NiCd 4C	151 + 151	139 + 139		530
Accu NiCd 5A	338	323		660
Accu NiCd 5B	151 + 218	139 + 201		660
Accu NiCd 6A	218 + 218	201 + 201		790

#### Batteries (side by side):

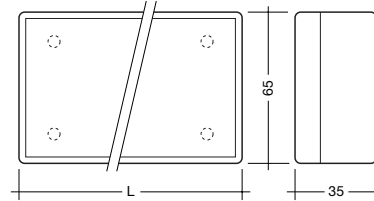

Type	length	fixing centres		weight (gms)
	L (mm)	D (mm)		
Accu NiCd 3B	98	40 x 33		400
Accu NiCd 4B	130	40 x 66		530

#### Wiring guidelines

To ensure that a luminaire containing high frequency emergency units complies with EN 55015 for radio frequency conducted interference in both normal and emergency mode it is essential to follow good practice in the wiring layout.

Within the luminaire the switched and unswitched 50 Hz supply wiring must be routed as short as possible and be kept as far away as possible from the lamp leads.

This means, for example, in a linear T8 or T5 luminaire the mains wiring should be routed along one side of the luminaire body, while the wires to the emergency lamp from the emergency module are routed along the other side.

The high frequency emergency lamp wiring contains "hot" leads at pins 1 and 6, which have high voltage to earth. These should be kept as short as possible and separated from other wiring to minimize coupling. They also have a restriction on capacitance to other wiring and earth of 100 pF, which must be observed to ensure good lamp starting.

With an earth connection of the metal case of the emergency module the noise suppression can be further improved. The wiring of the earth should be kept as short as possible.

Through wiring may affect the emc performance of the luminaire.

With the use of the fifth pole possible compatibility problems between the products can be prevented. Depending on the luminaire wiring the radio suppression in the emergency mode of operation can be further improved.

Capacitive loading limits of lamp leads must not be exceeded. Note the capacitance of the emergency lamp leads adds to the capacitance of the leads from the ballast to the EM BASIC module when considering ballast loading.

Circuit diagrams

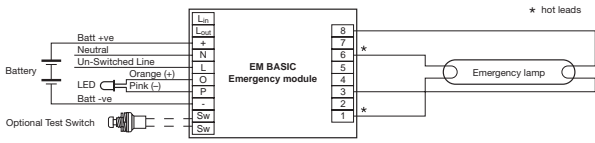

Non maintained

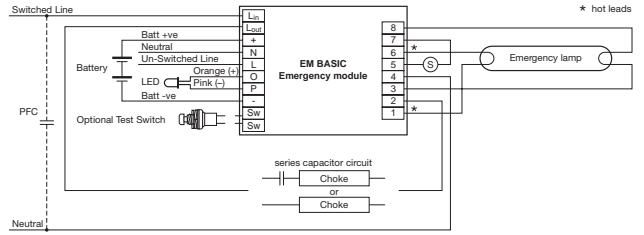

Single lamp switch start circuit with conventional control gear

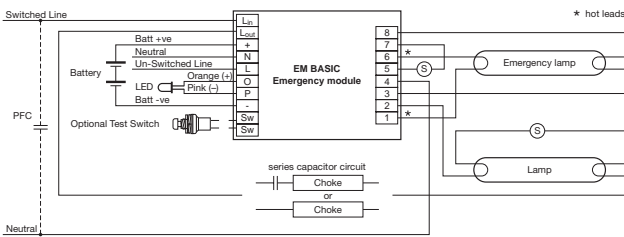

Twin series switch start circuit with conventional control gear

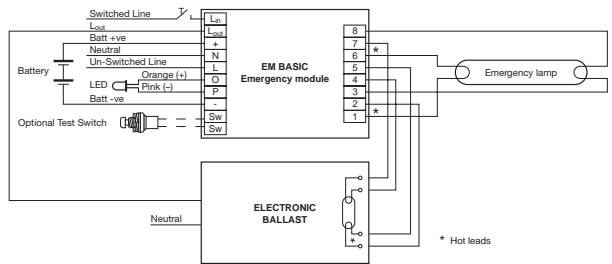

Single lamp high frequency electronic ballast

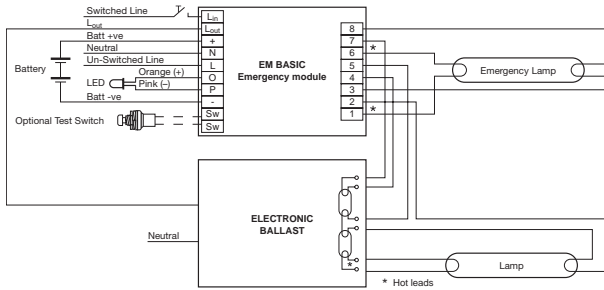

Twin lamp high frequency electronic ballast (6 lamp lead connections)

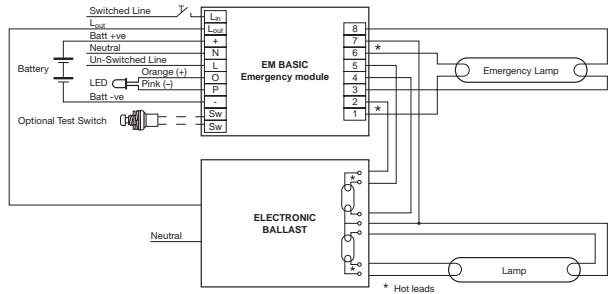

Twin lamp high frequency electronic ballast (7 lamp lead connections)

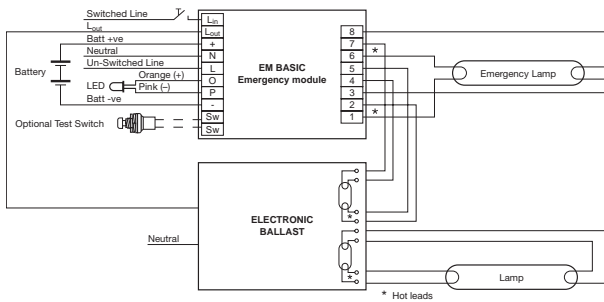

Twin lamp high frequency electronic ballast (8 lamp lead connections)