

PC TCL COMBO 220–240 V 50/60 Hz

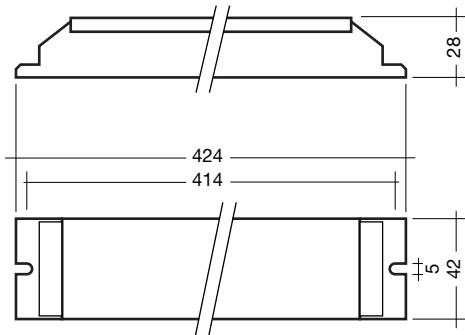

**Description:**

Warm start fixed output, combined electronic high frequency ballasts and emergency lighting modules for TC-L compact fluorescent lamps.

**Features:**

**Operation**

- Latest ballast technology
- Intelligent voltage guard (IVG)
- Preheat start in normal operation
- Automatic restart after lamp change in normal operation
- 3 hour duration
- NiCd or NiMH battery options
- Reverse battery polarity protected
- Battery short circuit protected

- Deep discharge protection
- Regulated electronic charging circuit
- Standard brightness and ultra high brightness (UHB) charge indicator LED available

**Easy to Use**

- Lightweight one piece unit
- Simplified wiring
- No compatibility issues
- IDC terminals for automatic and manual wiring
- Emergency testing by isolating only the unswitched supply
- Optional test switch

**Safe and Reliable**

- Automated manufacture
- Designed and manufactured to ISO 9001
- Complies with European Standards:
  - EN 55015: 2006 + A1: 2007 (EMC/Emitted RFI)
  - EN 61547 (EMC/Immunity)
  - EN 61000-3-2 (EMC/Supply Harmonics)
  - EN 61347-2-7 (Safety)
  - EN 61347-2-3 (Safety)
  - EN 60925 (Performance)
  - EN 60929 (Performance)
- In accordance with EN 50172 (Emergency escape lighting systems)
- In accordance with EN 60598-2-22
- Mains ballast complies with end of lamp life (EOL) test 2
- ENEC approved. CE marked

Note: The PC TCL COMBO is not intended to be used for high risk task area lighting

Lamp		Ballast															
type	watt-age W	type	article number	length L mm	fixing centres mm	weight kg	lamp power W	lamp current A ①	circuit power W	supply current A	power factor (ca.)	max. case temperature tc point °C	emergency operation BLF	emergency operation EBLF ②	normal operation BLF	duration h	number of cells
TC-L	1x36	PC 1x36-3 TCL COMBO	89899920	424	415	0.56	32	0.016	38.5	0.17	0.97	70	0.051	0.040	1.00	3	3
TC-L	2x36	PC 2x36-3 TCL COMBO	89899921	424	415	0.56	32	0.016	74.0	0.33	0.98	70	0.051	0.040	1.00	3	3
TC-L	1x40	PC 1x40-4 TCL COMBO	89899922	424	415	0.56	40	0.017	46.0	0.20	0.97	70	0.061	0.040	1.00	3	4
TC-L	2x40	PC 2x40-4 TCL COMBO	89899923	424	415	0.56	40	0.017	90.6	0.40	0.98	70	0.061	0.040	1.00	3	4
TC-L	1x55	PC 1x55-5 TCL COMBO	89899924	424	415	0.56	55	0.023	65.0	0.29	0.97	70	0.085	0.075	1.00	3	5
TC-L	2x55	PC 2x55-5 TCL COMBO	89899925	424	415	0.56	55	0.023	127.0	0.56	0.98	70	0.085	0.075	1.00	3	5

① In emergency operation

② According to EN 61347-2-7: 2006

Accu – 3 h duration

NiCd 4.0 Ah D cells	type of cells	number of cells	article number
Accu-NiCd 3A	stick	3	89895960
Accu-NiCd 4A	stick	4	89895961
Accu-NiCd 5A	stick	5	89895973
Accu-NiCd 5B	stick + stick	3 + 2	89895962
Accu-NiCd 6A	stick + stick	3 + 3	89895963

Other batteries are available

See catalogue or separate datasheet for further information

Technical data PC TCL COMBO

Ambient temperature range	0 °C to +50 °C
Maximum case temperature Tc	see table on page 1
Ingress protection	IP 20
Safety class	Class 1
Vibration test IEC 60068-2-64 Fh	
Bump test EIC 60068-2-29 Eb	
Humidity IEC 60068-2-30	

NiMH 4.0 Ah Cs cells	type of cells	number of cells	article number
Accu-NiMH 4Ah C 3A	stick	3	89899854
Accu-NiMH 4Ah C 4A	stick	4	89899850
Accu-NiMH 4Ah C 5A	stick	5	89899851
Accu-NiMH 4Ah C 6A	stick	6	89899852
Accu-NiMH 4Ah C 6C	stick + stick	3 + 3	89899853

Insulation testing (no flashover or breakdown must occur):

Up to 500 V DC between the phase and neutral conductors connected together and the earth.

High voltage insulation testing (1500 V AC) not recommended

Basic insulation between supply and battery circuit

Status indication

A green LED indicates that charging current is flowing into the battery.

type	article number
LED EM green	89899605
LED EM green, high brightness	89899756

Test switch

An optional test switch can be wired to the PC TCL COMBO. This can be used to check local operation of the luminaire.

type	article number
Test switch EM 2	89805227

Restarting after lamp replacement:

Note: Before servicing luminaires the mains supply should always be disconnected.

If faulty lamps are changed with the mains connected they can be made to restart automatically provided an interval of 2 seconds is left after removal.

Technical data for normal operation

Rated mains supply voltage	220-240 V
Mains frequency	50/60 Hz
Earth leakage current	< 0.5 mA

Lamp starting

type of start	pre-heat
min. lamp starting temperature	-15 °C
starting time	< 1.5 s
number of starts per lamp	ca. 20.000
average lamp life (acc. to IEC 60081)	13.000 to 15.000 h
Lamp operating frequency	> 40 kHz
Overvoltage protection	320 V for 1 h with IVG
Overvoltage indication (IVG)	starting at input voltage $\geq$ 306 V AC
Ballast lumen factor (BLF)	see table on page 1
Recharge period	24 h

Nominal charge current

NiCd D, NiMH Cs cells (3 h)	210 mA
Mains change over voltage	in accordance with EN 60598-2-22

Technical data for emergency operation

Min. lamp starting temperature	0 °C
Emergency light output factor (BLF)	see table on page 1
Battery design voltage	1.2 V per cell
Nominal discharge current (3 h)	1.1 A
Lamp operating frequency	> 17 kHz

**Technical data Accu-NiCd 4.0 Ah D cells:**

case temperature range	
to ensure 4 years life	0 °C → +55 °C
storage life in temperate conditions	4 years
battery voltage per cell	1,2 V
capacity	4.0 Ah

**Note:**

Care should be taken to ensure batteries and emergency units don't exceed their maximum temperatures.



**Intelligent Voltage Guard**

Intelligent Voltage Guard is the name of the new electronic monitor from TridonicAtco. This innovative feature of the new PC COMBO family of combined electronic ballasts and emergency lighting modules from TridonicAtco immediately shows if the mains voltage rises above a certain threshold. Measures can then be taken quickly to prevent damage to the control gear. If the mains voltage rises above 306 V the lamps start flashing on and off. This signal "demands" disconnection of the power supply to the lighting system.



**New PC COMBO with xitec processor**

Is the very latest in lighting management design technology. The lamp friendly warm start is delivering maximum lamp life and enables high switching frequency applications. Smallest power loss and new freedom in the lamp design thanks to convincing thermal management.



**Energy class CELMA EEI = A2**

PC TCL COMBO ignition technology (smart heating) optimises lamp start and ensures no energy is wasted. After the lamp has struck the filament heating is reduced automatically to a defined minimum value. This reduction in filament heating, saves energy, yet maintains the proper operating conditions for the lamp. The lamp is always operated within specification.



**Smart Heating (normal operation)**

Innovative heating circuit. Reduced filament heating after lamp has struck.

**Technical data Accu-NiMh 4.0 Ah Cs cells:**

case temperature range	
to ensure 4 years life	0 °C → +45 °C
storage life in temperate conditions	4 years
battery voltage per cell	1.2 V
capacity	4.0 Ah

**Working Voltage**

type	lamp type	wattage w	U <sub>out</sub>
PC 1x36-3 TCL COMBO	TC-L	1x36	300 V
PC 2x36-3 TCL COMBO	TC-L	2x36	300 V
PC 1x40-4 TCL COMBO	TC-L	1x40	300 V
PC 2x40-4 TCL COMBO	TC-L	2x40	300 V
PC 1x55-5 TCL COMBO	TC-L	1x55	300 V
PC 2x55-5 TCL COMBO	TC-L	2x55	300 V

**Ambient Temperature**

PC TCL COMBO

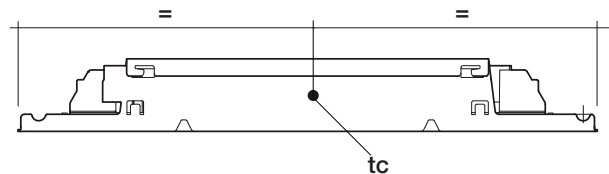

The nominal  $t_a$  and  $t_c$  point are related to the ballast life duration. The relation of  $t_c$  to  $t_a$  temperature depends also on the luminaire design. If the measured  $t_c$  temperature is approx. 5 K below  $t_c$  max.,  $t_a$  temperature should be checked and eventually critical components (e.g. ELCAP) measured. Detailed information on request.

**Service life**

PC TCL COMBO is designed for an average service life of 50,000 hours under reference conditions and with a failure probability of less than 10 %. This corresponds to an average failure rate of 0.2 % for every 1,000 hours of operation.

**CE marking:**

The PC TCL COMBO units are CE marked for compliance with the low voltage directive. Certificates of compliance are available to allow luminaires to be CE marked for compliance with the EMC directive.

**Mechanical details:**

Channel and Cover manufactured from 0.4 mm white pre-coated steel.

LED charge indicator

- Green
- Mounting hole 6.5 mm dia
- Length of LED lead 750 mm (Bezel supplied fitted to LED)

Test switch

- Mounting hole 7 mm dia
- Length of test switch lead 550 mm

**Electrical connections:**

In low temperature applications a starting aid is required for the emergency lamp which is referenced to the metal case of the unit. This starting aid does not need to be earthed.

The combined unit is intended to be earthed by the fixings used to attach it to the luminaire. It may also be earthed by a wire attached to the holes positioned in the sides at each end of the case channel.

Two different phases can be used as switched and unswitched line.

Note:

All electrical connections to the unit must be made when both permanent and switched mains supplies are disconnected

**Wiring advice**

The lead length is dependant on the capacitance of the cable.

For safety reasons, the PC T5 COMBO Ip must only be earthed in the case of a safety class 1 luminaire. Earthing is not required for the device to operate. Connection to earth reduces radio interference.

Type	Terminal		Maximum lead capacitance allowed	
	Cold	Hot	Cold	Hot
PC 1/xx TCL COMBO	3,4	1,2	100 pF	100 pF
PC 2/xx TCL COMBO	1,2,5,6	3,4	100 pF	100 pF

Battery leads

- Quantity: 1 red and 1 black
- Length: 1300 mm
- Wire type: 0.5 mm<sup>2</sup> solid conductor
- Insulation temperature rating: 90 °C

Termination 1

Push on 4.8 mm receptacle to suit battery spade fitted with insulating cover

Termination 2

9 mm stripped insulation

**Batteries:**

Connection method: 4.8 x 0.5 mm spade welded to end of cell

For the stick batteries this connection is accessible after the battery end caps have been fitted.

To inhibit inverter operation, only disconnect the batteries by removing the connector from the battery spade tags.

Note:

The battery charger of the PC TCL Combo is short circuit protected. After a battery short circuit the protection device will be resetted after a short while.

Battery must not be connected to earth.

**Packing quantities:**

PC TCL COMBO:  
25 pieces/carton  
28 cartons/pallet  
700 pieces/pallet

Accu NiCd / NiMH:  
25 pieces/carton

Test switch:  
25 pieces/bag  
200 pieces/carton

LED green:  
25 pieces/bag  
200 pieces/carton

**Storage:**

It is recommended to disconnect the battery before store or delivery. A long term storage in open circuit leads to battery self discharge and deactivation of chemical components. It could be required to charge and discharge the batteries a few times to recover the initial performance.

With standard solid wire 0.5/0.75 mm<sup>2</sup> the capacitance of the lead is 30–80 pF/m. This value is influenced by the way the wiring is made.

- keep lamp wires short
- lamp connection with multi-lamp ballasts should be made with symmetrical wiring
- for 1 and 2 lamp ballasts: hot leads and cold leads should be separated as much as possible
- The LED, test switch and battery wiring should be routed separately and kept as far away as possible from the high frequency lamp leads to avoid coupling.



**Installation instructions**

**IDC interface**

- solid wire with a cross section of 0.5 mm<sup>2</sup> according to the specification from WAGO

**Horizontal interface**

- solid wire with a cross section of 0.5–1.5 mm<sup>2</sup> according to the specification from WAGO
- strip 7.5–8.5 mm of insulation from the cables to ensure perfect operation of the terminals

**Note:**

To avoid the damage of the control gear, the wiring must be protected against short circuits to earth (sharp edged metal parts, metal cable clips, louver, etc.).

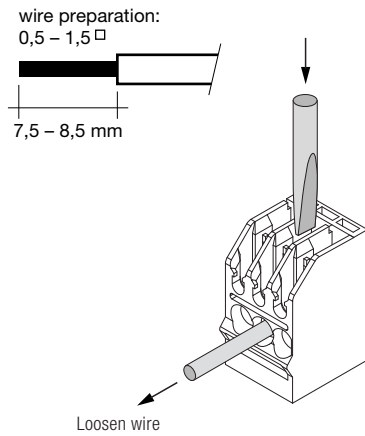

**RFI**

TridonicAtco ballasts are RFI protected in accordance with EN 55015: 2006 + A1: 2007. To operate the luminaire correctly and to minimise RFI we recommend the following instructions:

- Connection to the lamps of the “hot leads” must be kept as short as possible (marked with \*)
- Mains leads should be kept apart from lamp leads (ideally 5–10 cm distance)
- Do not run mains leads adjacent to the electronic ballast
- Twist the lamp leads
- Keep the distance of lamp leads from the metal work as large as possible
- Ballast should be earthed.
- Mains wiring to be twisted when through wiring
- Keep the mains leads inside the luminaire as short as possible

**PC TCL COMBO wiring diagrams**

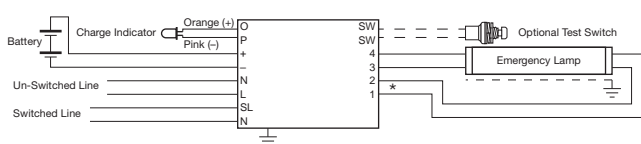

\* Hot lead length to be kept as short as possible  
Max lead capacitance of any lead 100 pF (1.0 m)

Wiring diagram PC TCL COMBO with single TC-L lamp

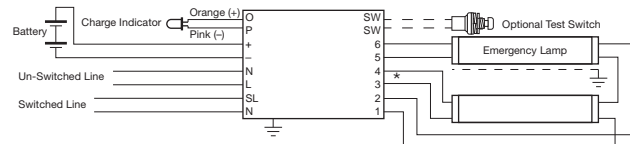

\* Hot lead length to be kept as short as possible  
Max lead capacitance of any lead 100 pF (1.0 m)

Wiring diagram PC TCL COMBO with twin TC-L lamp

① For further technical information please visit [www.tridonicatco.com](http://www.tridonicatco.com)