

TALEXengine EM-AP 001

RoHS

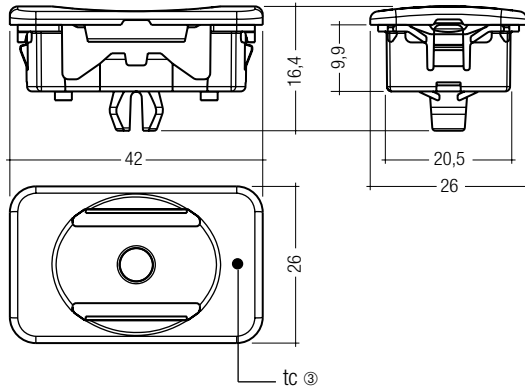

Applications:

- anti panic (open area) emergency lighting required illuminance according to EN1838: $E \geq 0.5$ lux

Highlights:

- latest generation LED light source
- long life thanks to integrated heat removal
- optimized system efficiency with broad beam characteristic
- integrated indicator LED
- integrated protection against reverse polarity
- different installation options: surface and recess mounting
- small dimensions

Properties:

- high-power LED in COB technology
- colour temperature white: ④
daylight white (DL): 6.500 K
- connection method: cable 260 mm
- identification of polarity: + red / – black
- protection rating IP 20

Operating unit:

EM powerLED

Packaging:

10 per box

type	article number	colour	colour temperature ④	light points per module	operating current mA ②	power W ① ⑤	ta °C	tc max °C ③	packaging unit
EM-AP 001	89600543	daylight white	6.500K	1	350	1,2	-20 → +50	60	10

all data for $t_a = 25$ °C (except max t_c)

① Tolerance range for optical and electrical data: +/- 15%

② Exceeding the maximum operating current leads to an overload on the TALEXengine EM-AP 001.

This may in turn result in a significant reduction in lifetime or even destruction of the TALEXengine EM-AP 001

③ If the maximum temperature limits are exceeded, the life of the module will be greatly reduced or the module may be damaged.

The temperature of the TALEXengine EM-AP 001 at the t_c point in the thermally stable state by means of a temperature sensor or temperature-sensitive sticker (available for example from www.conrad.com, www.rs-components.com) as per EN60598-1.

For the precise position of the t_c point see the above diagram.

④ For colour temperatures and tolerances see page 3

⑤ Data for operation with 350mA

Optical properties

Spacing for >0.5 lux for non maintained mode ①

height	centre to end ②	centre to centre ③
2.5 m	1.95 m	6.65 m
3.0 m	1.95 m	7.05 m
4.0 m	1.70 m	7.50 m
5.0 m	1.10 m	7.75 m

- ① maintenance factor = 0.89
photometric data (format LDT) available on request
- ② distance between module and wall
- ③ distance between two modules

Intensity distribution

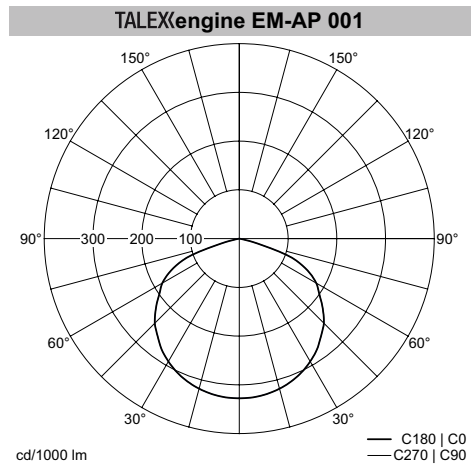

Mounting

Surface Mounting:

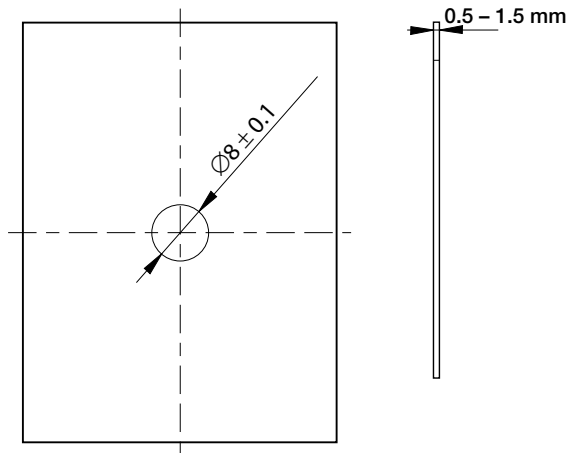
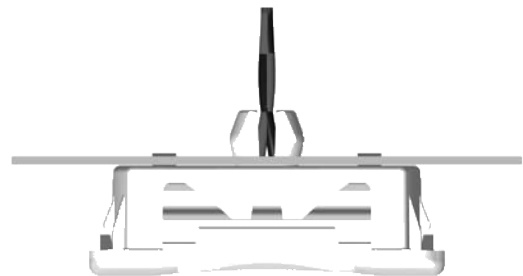

Plate thickness 0.5 – 1.5 mm



Recess Mounting:

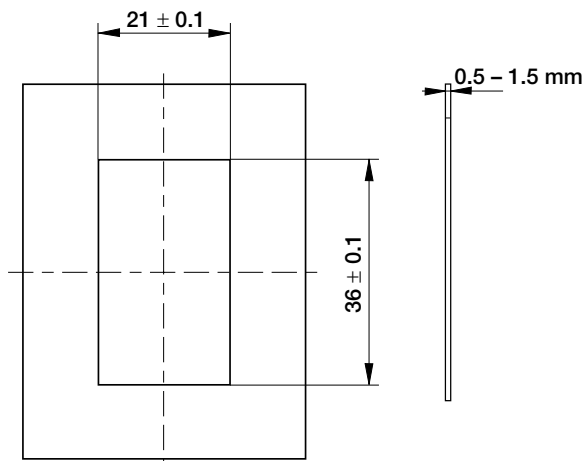
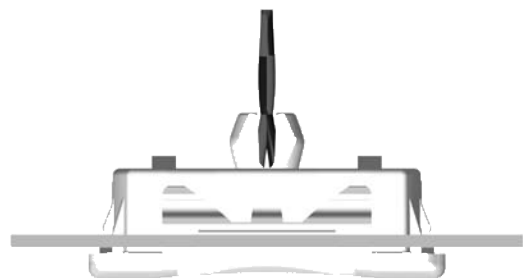

Plate thickness 0.5 – 1.5 mm



Electrical supply/choice of converter

TALEXengine EM-AP 001 modules from TridonicAtco are not protected against overvoltages, overcurrents, overloads or short-circuit currents. Safe and reliable operation can only be guaranteed in conjunction with a converter which complies with the relevant standards. The use of EM powerLED converters from TridonicAtco in combination with TALEXengine EM-AP 001 modules guarantees the necessary protection for safe and reliable operation.

If a converter other than TridonicAtco EM powerLED converter is used, it must provide the following protection:

- SELV
- Short-circuit protection
- Overload protection
- Overtemperature protection

The TALEXengine EM-AP 001 module must be supplied by a constant current converter. Operation with a constant voltage converter will lead to an irreversible damage of the module. The TALEXengine EM-AP 001 modules is protected against reversed polarity.

Cabeling:

- RED powerLED +
- BLACK powerLED –
- ORANGE Indicator LED
- PINK Indicator LED

Notes:

The Cabeling acc. to the information above is valid for the usage in conjunction with EM powerLED ST and EM powerLED PRO.

When the EM AP is used with the EM powerLED BASIC the polarity of the indicator LED has to be changed. Connect the orange lead to the terminal "P" and the pink lead to the terminal "O".

When two EM AP module are used with an EM powerLED 2W only one indicator LED can be connected to the driver.

Wiring example

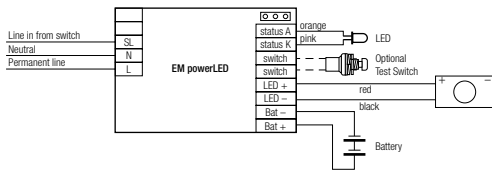

Corresponding colour temperature and CIE coordinates 6,500 K

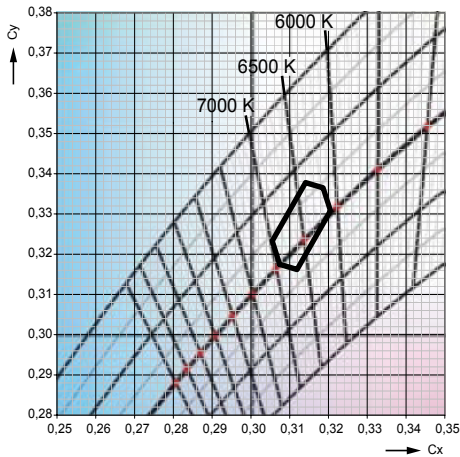

CIE coordinates: tolerance area

daylight white, 6,500 K

	Cx	Cy
tolerance area	0.3074	0.3175
	0.3055	0.3233
	0.3141	0.3378
	0.3186	0.3365
	0.3205	0.3308
	0.3119	0.3162