

Electronic ballasts for dimming to 1 %
Linear lamps T5, 16 mm high output

PCA T5 ECO Ip 24–80 W 220–240 V 50/60/0 Hz, dimmable

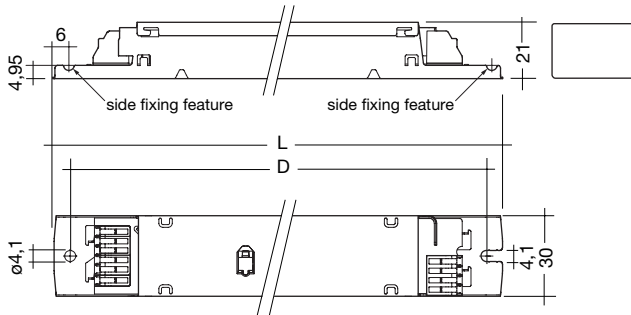

- cross section 21 x 30 mm
- dimming range from 1–100 %
- lamp start at 1 % possible
- lamp friendly warm start within 0.5 s with AC and 0.2 s with DC
- low power consumption in standby mode 0.8 W
- powerless switching through digital interface
- dimming which is comfortable to the eye
- disturbance free precise control with a digital signal (**DSI**) or switch**DIM**
- integrated SMART interface
- fully digital lamp management and digital communication

- Intelligent Voltage Guard (over voltage indication and under voltage protection)
- Intelligent Temperature Guard (Protection against thermal failure)
- DC operation in emergency lighting installations according to EN 50172

Programmable features:

- DC level programmable
- backwards compatibility adjustable
- adjustable dimming speed in switch**DIM** operation (3 s or 6 s)
- **NEW:** with switch**DIM** memory and corridor**FUNCTION**

Packaging:
360 mm housing
box of 10
76 boxes/pallet
760 pieces/pallet

425 mm housing
box of 25
33 boxes/pallet
825 pieces/pallet

Certified:
EN 55015
EN 55022
EN 60929
EN 61000-3-2
EN 61347-2-3
EN 61547
Suitable for emergency installations according to EN 50172

Lamp		Ballast										
wattage W	length	type	article number	length L mm	fixing centres D mm	weight kg	circuit power W ②	lamp power W ②	current at 230V/50Hz A ②	λ at 230V/50Hz	tc point °C	temperature range ① °C
24	549	PCA 1/24 T5 ECO Ip 220–240V 50/60/0Hz	22089521	360	350	0.27	26.7	23	0.12	0.96	80	-25 → +60
2x24	549	PCA 2/24 T5 ECO Ip 220–240V 50/60/0Hz	22089537	360	350	0.29	53.4	2x23	0.24	0.98	85	-25 → +60
39	849	PCA 1/39 T5 ECO Ip 220–240V 50/60/0Hz	22089506	360	350	0.27	41.3	38	0.19	0.97	80	-25 → +60
2x39	849	PCA 2/39 T5 ECO Ip 220–240V 50/60/0Hz	22089515	425	415	0.33	83.6	2x38	0.37	0.98	85	-25 → +60
49	1449	PCA 1/49 T5 ECO Ip 220–240V 50/60/0Hz	22089483	360	350	0.27	54.0	49	0.24	0.98	75	-25 → +50
2x49	1449	PCA 2/49 T5 ECO Ip 220–240V 50/60/0Hz	22089499	425	415	0.36	106.1	2x49	0.47	0.99	85	-25 → +60
54	1149	PCA 1/54 T5 ECO Ip 220–240V 50/60/0Hz	22089461	360	350	0.27	59.7	54	0.26	0.99	80	-25 → +50
2x54	1149	PCA 2/54 T5 ECO Ip 220–240V 50/60/0Hz	22089477	425	415	0.36	117.9	2x54	0.52	0.99	85	-25 → +50
80	1449	PCA 1/80 T5 ECO Ip 220–240V 50/60/0Hz	22089458	425	415	0.31	86.3	80	0.38	0.99	80	-25 → +50
2x80	1449	PCA 2/80 T5 ECO Ip 220–240V 50/60/0Hz	22176054	425	415	0.35	167.0	2x80	0.75	0.99	80	-25 → +50

① 10 °C to ta max: normal dimming operation

-25 °C to +10 °C: dimming operation from 100 % to 30 %.

-25 °C to +10 °C, dimming below 30 %: Ballast could shut down but will not cause failure. This relates to AC and DC operation.

② valid at 100 % light output

Lamp starting characteristics:

Warm start
Starting time 0.5 s with AC
Starting time 0.2 s with DC
Start at any dimming level



Intelligent Voltage Guard

Intelligent Voltage Guard is the name of the new electronic monitor from TridonicAtco. This innovative feature of the PCA family of control gear from TridonicAtco immediately shows if the mains voltage rises above or falls below certain thresholds. Measures can then be taken quickly to prevent damage to the control gear.

- If the mains voltage rises above ≥ 305 V the lamps start flashing on and off.
- This signal "demands" disconnection of the power supply to the lighting system.
- The active-current-control of these control gears is protected against failure caused by the high mains currents generated as a result of mains undervoltage. The switch off level depends on lamp wattage and is typically < 140 V.



Intelligent Temperature Guard

The intelligent temperature guard protects the ballast from thermal failure by reducing output power or switching off in case of operation above the thermal limits of the luminaire or ballast. Depending on the luminaire design, the ITG operates at about 5 to 10 °C above Tc temperature.



corridorFUNCTION

To activate the corridorFUNCTION a voltage of 230 V simply has to be applied for five minutes at the switchDIM connection. The unit will then switch automatically to the corridorFUNCTION. Note: If the corridorFUNCTION is wrongly activated in a switchDIM system (for example a switch is used instead of pushbutton), there is the option of installing a pushbutton and deactivating the corridorFUNCTION mode by five short pushes of the button within three seconds.

AC operation:

Mains voltage
220–240 V 50/60 Hz
198–264 V 50/60 Hz including safety tolerance (± 10 %)
202–254 V 50/60 Hz including performance tolerance ($+6$ % / -8 %)

Emergency devices:

Ballasts from the "low profile" series are compatible with all emergency units from TridonicAtco. See the table in the data sheet. When used with other emergency units tests are necessary.

Mains currents in DC operation

Ballast Typ	Mains current at $U_n = 220$ VDC	Mains current at $U_n = 240$ VDC
PCA 1/24 T5 ECO Ip 220–240V 50/60/0Hz	0.10 A	0.09 A
PCA 1/39 T5 ECO Ip 220–240V 50/60/0Hz	0.15 A	0.14 A
PCA 1/49 T5 ECO Ip 220–240V 50/60/0Hz	0.20 A	0.18 A
PCA 1/54 T5 ECO Ip 220–240V 50/60/0Hz	0.28 A	0.25 A
PCA 1/80 T5 ECO Ip 220–240V 50/60/0Hz	0.40 A	0.37 A
PCA 2/24 T5 ECO Ip 220–240V 50/60/0Hz	0.20 A	0.19 A
PCA 2/39 T5 ECO Ip 220–240V 50/60/0Hz	0.29 A	0.27 A
PCA 2/49 T5 ECO Ip 220–240V 50/60/0Hz	0.38 A	0.35 A
PCA 2/54 T5 ECO Ip 220–240V 50/60/0Hz	0.55 A	0.50 A
PCA 2/80 T5 ECO Ip 220–240V 50/60/0Hz	0.79 A	0.72 A

Light output level in DC operation:

Programmable from 1 % to 70 %
Programming by extended DSI-Signal (16 Bit)
Default value 70 %
In DC operation dimming mode can be activated.

Ballast lumen factor AC operation (AC-BLF) EN 60929 Pkt.8.1:

Ballast Typ	AC-BLF at $U_n = 230$ VAC
PCA 1/24 T5 ECO Ip 220–240V 50/60/0Hz	1.00
PCA 1/39 T5 ECO Ip 220–240V 50/60/0Hz	1.01
PCA 1/49 T5 ECO Ip 220–240V 50/60/0Hz	0.97
PCA 1/54 T5 ECO Ip 220–240V 50/60/0Hz	0.99
PCA 1/80 T5 ECO Ip 220–240V 50/60/0Hz	1.04
PCA 2/24 T5 ECO Ip 220–240V 50/60/0Hz	1.01
PCA 2/39 T5 ECO Ip 220–240V 50/60/0Hz	1.00
PCA 2/49 T5 ECO Ip 220–240V 50/60/0Hz	0.98
PCA 2/54 T5 ECO Ip 220–240V 50/60/0Hz	1.00
PCA 2/80 T5 ECO Ip 220–240V 50/60/0Hz	1.00

The ballast lumen factor for AC operation (AC-BLF) does not alter from $U_n = 198$ VAC bis $U_n = 254$ VAC.

The ballast lumen factor for DC operation (DC-BLF) on the basis of an automatic power reduction of the ballasts (default value is 70%) will be smaller than AC. It does not alter in the DC operating range (198–280 VDC).

Harmonic distortion in the mains supply (at 220 V / 50 Hz):

Ballast Typ	THD	3	5	7	9	11
PCA 1/24 T5 ECO Ip 220–240V 50/60/0Hz	6.7	4.5	1.8	1.9	1.6	1.8
PCA 1/39 T5 ECO Ip 220–240V 50/60/0Hz	8.2	6.2	2.9	1.7	1.5	1.2
PCA 1/49 T5 ECO Ip 220–240V 50/60/0Hz	6.5	4.8	1.8	1.4	1.1	1.4
PCA 1/54 T5 ECO Ip 220–240V 50/60/0Hz	8.6	5.9	3.2	1.6	1.2	1.4
PCA 1/80 T5 ECO Ip 220–240V 50/60/0Hz	8.2	6.7	1.4	2.2	1.1	1.3
PCA 2/24 T5 ECO Ip 220–240V 50/60/0Hz	5.5	2.8	1.1	2.1	1.5	1.7
PCA 2/39 T5 ECO Ip 220–240V 50/60/0Hz	5.5	3.3	1.5	2.2	1.4	1.5
PCA 2/49 T5 ECO Ip 220–240V 50/60/0Hz	5.4	3.9	1.0	1.5	1.0	1.3
PCA 2/54 T5 ECO Ip 220–240V 50/60/0Hz	7.5	6.1	0.8	1.8	1.1	1.3
PCA 2/80 T5 ECO Ip 220–240V 50/60/0Hz	6.8	5.4	4.1	0.8	0.8	0.7

Dimming:

Dimming curve that is friendly to the eye
Dimming range 1 % to 100 %
Digital control with DSI signal:
8 Bit Manchester Code
Speed 1 % to 100 % in 1.4 s

Control input (D1, D2):

Digital DSI signal or switchDIM can be wired on the same terminals (D1 and D2).

Digital signal DSI:

The control input is non-polar and protected against accidental connection with a mains voltage up to 264 V. The control signal is not SELV. Control cable should be installed in accordance to the requirements of low voltage installations.
Different functions depending on each module.

SMART interface:

An additional interface for the direct connection of the SMART-LS II Ip¹⁾ light sensor. The sensor registers actual ambient light and maintains the individually defined lux level.
After every mains reset the SMART interface automatically checks for an installed sensor. With the sensor installed the PCA T5 ECO Ip automatically runs in the constant lux level mode.
ON/OFF-Switch via mains, switchDIM or DSI signal.
DSI signal = 0 switches off,
DSI signal ≥ 1 switches on.
With switchDIM signals it is possible to change the controlled light level temporarily.
Temporarily means that after a switching cycle OFF/ON command the PCA T5 ECO Ip will start at the preset value determined by the SMART-LS II Ip¹⁾. This preset can be set mechanically directly on the SMART-LS II Ip¹⁾.
The installation of the two wire bus is according to the appropriate low voltage regulations.

¹⁾ SMART-LS II Ip: article number 86458258

Dimming characteristics PCA ECO

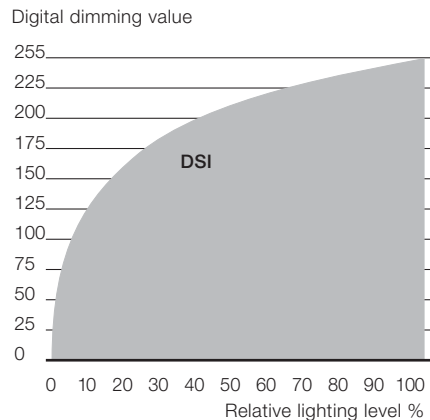

■ Dimming characteristics as seen by the human eye

Energy Savings PCA ECO

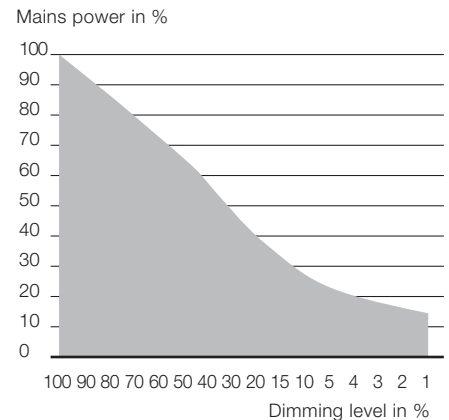

switchDIM:

Integrated switchDIM function allows a direct connection of a push to make switch for dimming and switching.
Brief push (< 0.6 s) switches ballast ON and OFF. The ballasts switch-ON at light level set at switch-OFF.
When the push to make switch is held, PCA ballasts are dimmed. After repush the PCA is dimmed in the opposite direction.
The switchDIM fade time is set to 3 s from min. to max. in the factory settings. With a 20 s push to the push to make switch this fade time can be changed to 6 s. In this instance the switchDIM application will be synchronized to 50 % light level after 10 s and after 20 s the light level rises to 100 % with the new fade time.
In installations with PCAs with different dimming levels or opposite dimming directions (e.g. after a system extension), all PCAs can be synchronized to 50 % dimming level by a 10 s push.
Use of push to make switch with indicator lamp is not permitted.

Backwards compatibility:

With a simple key combination a PCA ECO Ip can be reset as a normal PCA ECO from the previous generation. Synchronisation simply has to take place three times within one minute (3x10 s). To activate the "Ip" settings again, synchronisation has to take place four times within one minute.

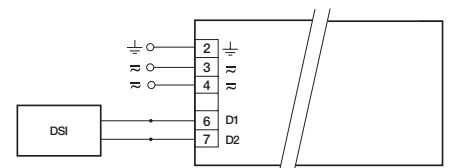

DSI PCA T5 ECO Ip

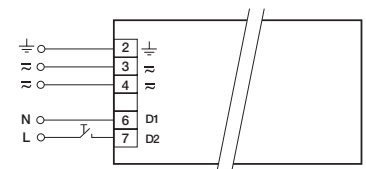

switchDIM PCA T5 ECO Ip

Loading of automatic circuit breakers:

Automatic circuit	C10	C13	C16	C20	B10	B13	B16	B20
Installation Ø	1.5 mm ²	1.5 mm ²	1.5 mm ²	2.5 mm ²	1.5 mm ²	1.5 mm ²	1.5 mm ²	2.5 mm ²
PCA 1/24 T5 ECO Ip	50	80	150	180	25	40	75	90
PCA 1/39 T5 ECO Ip	34	50	70	86	17	25	38	43
PCA 1/49 T5 ECO Ip	24	34	48	52	12	17	24	26
PCA 1/54 T5 ECO Ip	24	34	48	52	12	17	24	26
PCA 1/80 T5 ECO Ip	14	20	28	28	7	10	14	14
PCA 2/24 T5 ECO Ip	24	34	48	52	12	17	24	26
PCA 2/39 T5 ECO Ip	16	22	30	32	8	11	15	16
PCA 2/49 T5 ECO Ip	12	18	26	26	6	9	13	13
PCA 2/54 T5 ECO Ip	12	18	26	26	6	9	13	13
PCA 2/80 T5 ECO Ip	10	14	20	22	5	7	10	11

**Electronic ballasts for dimming to 1 %
Linear lamps T5, 16 mm high output**

Installation instructions:

Wiring type and cross section:

The wiring can be solid cable with a cross section of 0.5 to 0.75 mm² for push terminal and 0.5 mm² for concut terminal. For the push-wire connection you have to strip the insulation (8–9 mm).

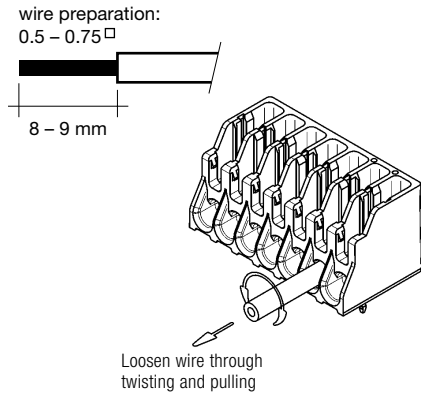

Ballast Typ	U _{out}
PCA 1/24 T5 ECO Ip	220–240V 50/60/0Hz 300 V
PCA 1/39 T5 ECO Ip	220–240V 50/60/0Hz 400 V
PCA 1/49 T5 ECO Ip	220–240V 50/60/0Hz 460 V
PCA 1/54 T5 ECO Ip	220–240V 50/60/0Hz 460 V
PCA 1/80 T5 ECO Ip	220–240V 50/60/0Hz 460 V
PCA 2/24 T5 ECO Ip	220–240V 50/60/0Hz 430 V
PCA 2/39 T5 ECO Ip	220–240V 50/60/0Hz 460 V
PCA 2/49 T5 ECO Ip	220–240V 50/60/0Hz 460 V
PCA 2/54 T5 ECO Ip	220–240V 50/60/0Hz 460 V
PCA 2/80 T5 ECO Ip	220–240V 50/60/0Hz 430 V

RFI:

- Connection to the lamps of the hot leads must be kept as short as possible
- Mains leads should be kept apart from lamp leads (ideally 5–10 cm distance)
- Do not run mains leads adjacent to the electronic ballast
- Twist the lamp leads
- Keep the distance of lamp leads from the metal work as large as possible
- Mains wiring to be twisted when through wiring
- Keep the mains leads inside the luminaire as short as possible

General advise:

Electronic ballasts are virtually noise free. Magnetic fields generated during the ignition cycle can cause some background noise but only for a few milliseconds.

① For further technical information please visit www.tridonicatco.com

Wiring advice:

The lead length is dependent on the capacitance of the cable.

Ballast Type	Terminal		Maximum capacitance allowed	
	Cold	Hot	Cold	Hot
PCA 1/xx T5 ECO Ip	11, 12	9, 10	200 pF	100 pF
PCA 2/xx T5 ECO Ip	11, 12, 13, 14	9, 10, 15, 16	200 pF	100 pF

With standard solid wire 0.5/0.75 mm² the capacitance of the lead is 30–80 pF/m.

This value is influenced by the way the wiring is made.

Lamp connection should be made with symmetrical wiring.

Hot leads (9, 10, 15, 16) and cold leads (11, 12, 13, 14) should be separated as much as possible.

When using two or more dimmable ballasts in one luminaire with separate dimming controls, the lamp leads must be kept separate.

Dimmable ballasts from TridonicAtco have to be earthed.

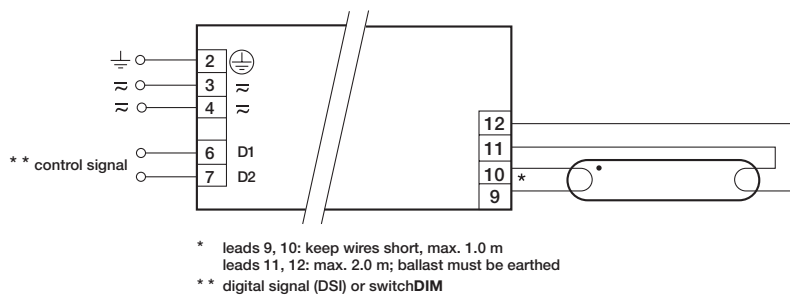

PCA T5 ECO Ip 24–80 W

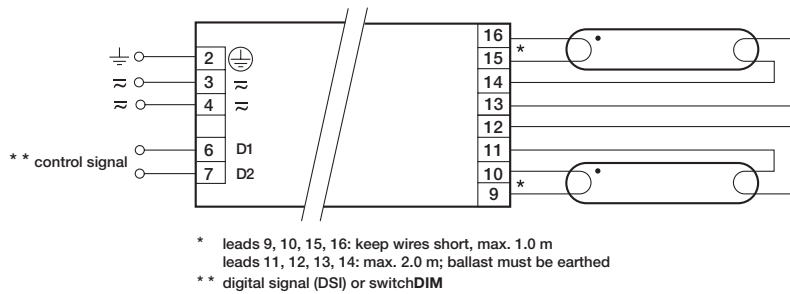

PCA T5 ECO Ip 2x24–2x80 W