

Electronic ballasts for dimming to 1 %
Linear lamps T5, 16 mm high output

PCA T5 EXCEL one4all Ip 24–80 W 220–240 V 50/60/0 Hz, dimmable

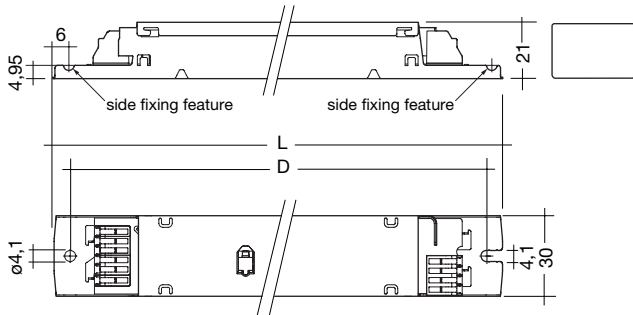

- cross section 21 x 30 mm
- dimming range from 1–100 %
- lamp start at 1 % possible
- lamp friendly warm start within 0.5 s with AC and 0.2 s with DC
- low power consumption in standby mode < 0.5 W (0.8 W in DSI or switchDIM mode)
- powerless switching through digital interface
- dimming which is comfortable to the eye
- disturbance free precise control with a digital signal (DSI), switchDIM or DALI (digital addressable lighting interface)
- error feed back and programmable features in both DALI and DSI mode (2x80 W only DALI)
- integrated SMART interface
- fully digital lamp management and digital communication

- Intelligent Voltage Guard (over voltage indication and under voltage protection)
- Intelligent Temperature Guard (Protection against thermal failure)
- DC operation in emergency lighting installations according to EN 50172

Programmable features:

- DC level programmable
- dimming in DC mode can be chosen
- backwards compatibility adjustable
- adjustable dimming speed in switchDIM operation (3 s or 6 s)
- smart heating concept enables fastest fade times (50 ms from min → max or reverse)
- **NEW:** with DALI memory and corridorFUNCTION

Packaging:

360 mm housing
box of 10
76 boxes/pallet
760 pieces/pallet

425 mm housing
box of 25
33 boxes/pallet
825 pieces/pallet

Certified:

EN 55015
EN 55022
EN 60929
EN 61000-3-2
EN 61347-2-3
EN 61547
Suitable for emergency installations according to EN 50172

Lamp		Ballast										
wattage W	length	type	article number	length L mm	fixing centres D mm	weight kg	circuit power W ②	lamp power W ②	current at 230V/50Hz A ②	λ at 230V/50Hz	tc point °C	temperature range ① °C
24	549	PCA 1/24 T5 EXCEL Ip 220–240V 50/60/0Hz	22088607	360	350	0.27	26.7	23	0.12	0.96	80	-25 → +60
2x24	549	PCA 2/24 T5 EXCEL Ip 220–240V 50/60/0Hz	22088616	360	350	0.29	53.4	2x23	0.24	0.98	85	-25 → +60
39	849	PCA 1/39 T5 EXCEL Ip 220–240V 50/60/0Hz	22088580	360	350	0.27	41.3	38	0.19	0.97	80	-25 → +60
2x39	849	PCA 2/39 T5 EXCEL Ip 220–240V 50/60/0Hz	22088596	425	415	0.33	83.6	2x38	0.37	0.98	85	-25 → +60
49	1449	PCA 1/49 T5 EXCEL Ip 220–240V 50/60/0Hz	22088568	360	350	0.27	54.0	49	0.24	0.98	75	-25 → +50
2x49	1449	PCA 2/49 T5 EXCEL Ip 220–240V 50/60/0Hz	22088574	425	415	0.36	106.1	2x49	0.47	0.99	85	-25 → +60
54	1149	PCA 1/54 T5 EXCEL Ip 220–240V 50/60/0Hz	22088549	360	350	0.27	59.7	54	0.26	0.99	80	-25 → +50
2x54	1149	PCA 2/54 T5 EXCEL Ip 220–240V 50/60/0Hz	22088555	425	415	0.36	117.9	2x54	0.52	0.99	85	-25 → +50
80	1449	PCA 1/80 T5 EXCEL Ip 220–240V 50/60/0Hz	22088533	425	415	0.31	86.3	80	0.38	0.99	80	-25 → +50
2x80	1449	PCA 2/80 T5 EXCEL Ip 220–240V 50/60/0Hz	22176053	425	415	0.35	167.0	2x80	0.75	0.99	80	-25 → +50

① 10 °C to ta max: normal diming operation

-25 °C to +10 °C: dimming operation from 100 % to 30 %.

-25 °C to +10 °C, dimming below 30 %: Ballast could shut down but will not cause failure. This relates to AC and DC operation.

② valid at 100 % light output

Lamp starting characteristics:

Warm start
Starting time 0.5 s with AC
Starting time 0.2 s with DC
Start at any dimming level



Intelligent Voltage Guard

Intelligent Voltage Guard is the name of the new electronic monitor from TridonicAtco. This innovative feature of the PCA family of control gear from TridonicAtco immediately shows if the mains voltage rises above or falls below certain thresholds. Measures can then be taken quickly to prevent damage to the control gear.

- If the mains voltage rises above ≥ 305 V the lamps start flashing on and off.
- This signal "demands" disconnection of the power supply to the lighting system.
- The active-current-control of these control gears is protected against failure caused by the high mains currents generated as a result of mains undervoltage. The switch off level depends on lamp wattage and is typically < 140 V.



Intelligent Temperature Guard

The intelligent temperature guard protects the ballast from thermal failure by reducing output power or switching off in case of operation above the thermal limits of the luminaire or ballast. Depending on the luminaire design, the ITG operates at about 5 to 10 °C above Tc temperature.



corridorFUNCTION

The corridorFUNCTION can be programmed in two different ways.

To program the corridorFUNCTION by means of software a DALI-USB interface is needed in combination with a DALI PS. The software can be the configTOOL, the pcaCONFIGURATOR or the corridorFUNCTION CONFIGURATOR. To activate the corridorFUNCTION without using software a voltage of 230 V simply has to be applied for five minutes at the switchDIM connection. The unit will then switch automatically to the corridorFUNCTION.

Note: If the corridorFUNCTION is wrongly activated in a switchDIM system (for example a switch is used instead of pushbutton), there is the option of installing a pushbutton and deactivating the corridorFUNCTION mode by five short pushes of the button within three seconds.

AC operation:

Mains voltage
220–240 V 50/60 Hz
198–264 V 50/60 Hz including safety tolerance (± 10 %)
202–254 V 50/60 Hz including performance tolerance ($+6$ % / -8 %)

DC operation:

220–240 V 0 Hz
198–280 V 0 Hz certain lamp start
176–280 V 0 Hz operating range
Use in emergency lighting installations according to EN 50172 or for emergency luminaires according to EN 61347-2-3 appendix J.

Emergency devices:

Ballasts from the "low profile" series are compatible with all emergency units from TridonicAtco. See the table in the data sheet. When used with other emergency units tests are necessary.

Temperature range:

Unlimited dimming range from 10 °C to ta max.
Limited dimming range from -25 °C to +10 °C.

Mains currents in DC operation

Ballast Typ	Mains current at $U_n = 220$ VDC	Mains current at $U_n = 240$ VDC
PCA 1/24 T5 EXCEL Ip 220–240V 50/60/0Hz	0.10 A	0.09 A
PCA 1/39 T5 EXCEL Ip 220–240V 50/60/0Hz	0.15 A	0.14 A
PCA 1/49 T5 EXCEL Ip 220–240V 50/60/0Hz	0.20 A	0.18 A
PCA 1/54 T5 EXCEL Ip 220–240V 50/60/0Hz	0.28 A	0.25 A
PCA 1/80 T5 EXCEL Ip 220–240V 50/60/0Hz	0.40 A	0.37 A
PCA 2/24 T5 EXCEL Ip 220–240V 50/60/0Hz	0.20 A	0.19 A
PCA 2/39 T5 EXCEL Ip 220–240V 50/60/0Hz	0.29 A	0.27 A
PCA 2/49 T5 EXCEL Ip 220–240V 50/60/0Hz	0.38 A	0.35 A
PCA 2/54 T5 EXCEL Ip 220–240V 50/60/0Hz	0.55 A	0.50 A
PCA 2/80 T5 EXCEL Ip 220–240V 50/60/0Hz	0.79 A	0.72 A

Light output level in DC operation:

Programmable from 1 % to 70 %
Programming by extended DSI-Signal (16 Bit)
Default value 70 %
In DC operation dimming mode can be activated.

Ballast lumen factor AC operation (AC-BLF) EN 60929 Pkt.8.1:

Ballast Typ	AC-BLF at $U_n = 230$ VAC
PCA 1/24 T5 EXCEL Ip 220–240V 50/60/0Hz	1.00
PCA 1/39 T5 EXCEL Ip 220–240V 50/60/0Hz	1.01
PCA 1/49 T5 EXCEL Ip 220–240V 50/60/0Hz	0.97
PCA 1/54 T5 EXCEL Ip 220–240V 50/60/0Hz	0.99
PCA 1/80 T5 EXCEL Ip 220–240V 50/60/0Hz	1.04
PCA 2/24 T5 EXCEL Ip 220–240V 50/60/0Hz	1.01
PCA 2/39 T5 EXCEL Ip 220–240V 50/60/0Hz	1.00
PCA 2/49 T5 EXCEL Ip 220–240V 50/60/0Hz	0.98
PCA 2/54 T5 EXCEL Ip 220–240V 50/60/0Hz	1.00
PCA 2/80 T5 EXCEL Ip 220–240V 50/60/0Hz	1.00

The ballast lumen factor for AC operation (AC-BLF) does not alter from $U_n = 198$ VAC bis $U_n = 254$ VAC.

The ballast lumen factor for DC operation (DC-BLF) on the basis of an automatic power reduction of the ballasts (default value is 70%) will be smaller than AC. It does not alter in the DC operating range (198–280 VDC).

Harmonic distortion in the mains supply (at 220 V / 50 Hz):

Ballast Typ	THD	3	5	7	9	11
PCA 1/24 T5 EXCEL Ip 220–240V 50/60/0Hz	6.7	4.5	1.8	1.9	1.6	1.8
PCA 1/39 T5 EXCEL Ip 220–240V 50/60/0Hz	8.2	6.2	2.9	1.7	1.5	1.2
PCA 1/49 T5 EXCEL Ip 220–240V 50/60/0Hz	6.5	4.8	1.8	1.4	1.1	1.4
PCA 1/54 T5 EXCEL Ip 220–240V 50/60/0Hz	8.6	5.9	3.2	1.6	1.2	1.4
PCA 1/80 T5 EXCEL Ip 220–240V 50/60/0Hz	8.2	6.7	1.4	2.2	1.1	1.3
PCA 2/24 T5 EXCEL Ip 220–240V 50/60/0Hz	5.5	2.8	1.1	2.1	1.5	1.7
PCA 2/39 T5 EXCEL Ip 220–240V 50/60/0Hz	5.5	3.3	1.5	2.2	1.4	1.5
PCA 2/49 T5 EXCEL Ip 220–240V 50/60/0Hz	5.4	3.9	1.0	1.5	1.0	1.3
PCA 2/54 T5 EXCEL Ip 220–240V 50/60/0Hz	7.5	6.1	0.8	1.8	1.1	1.3
PCA 2/80 T5 EXCEL Ip 220–240V 50/60/0Hz	6.8	5.4	4.1	0.8	0.8	0.7

Dimming:

Dimming curve that is friendly to the eye

Dimming range 1 % to 100 %

Digital control with

- DSI-Signal: 8 Bit Manchester Code
Speed 1 % to 100 % in 1.4 s
 - DALI-Signal: 16 Bit Manchester Code
Speed 1 % to 100 % in 550 ms (adjustable between 50 ms and 90 s)
- Programmable parameter:
Minimum dimming level
Maximum dimming level
Default minimum = 1 %
Programmable Range 1 % ≤ MIN ≤ 49 %
Default Maximum = 100 %
Programmable Range 100 % ≥ MAX ≥ 50 %

Control input (DA/D1, DA/D2):

Digital DALI/DSI signal or switchDIM can be wired on the same terminals (DA/D1 and DA/D2).

Digital signal DALI/DSI:

The control input is non-polar and protected against accidental connection with a mains voltage up to 264V. The control signal is not SELV. Control cable should be installed in accordance to the requirements of low voltage installations.

Different functions depending on each module.

SMART interface:

An additional interface for the direct connection of the SMART-LS II Ip¹⁾ light sensor. The sensor registers actual ambient light and maintains the individually defined lux level.

After every mains reset the SMART interface automatically checks for an installed sensor. With the sensor installed the PCA T5 EXCEL one4all Ip automatically runs in the constant lux level mode. ON/OFF-Switch via mains, switchDIM or DALI/DSI signal.

DALI/DSI signal = 0 switches off,

DALI/DSI signal ≥ 1 switches on.

With relative DALI dimming commands (e.g. up, down etc.) or switchDIM signals it is possible to change the controlled light level temporarily.

Temporarily means that after a switching cycle OFF/ON command the PCA T5 EXCEL one4all Ip will start at the preset value determined by the SMART-LS II Ip¹⁾. This preset can be set mechanically directly on the SMART-LS II Ip¹⁾.

¹⁾ SMART-LS II Ip: article number 86458258

Dimming characteristics PCA EXCEL

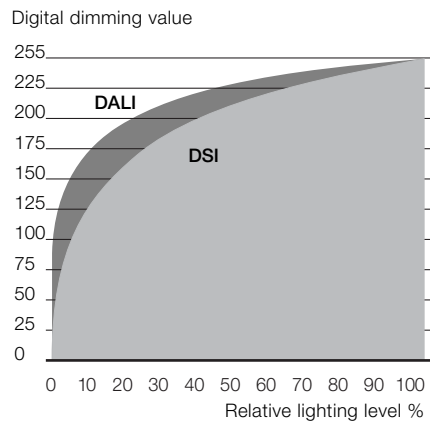

Dimming characteristics as seen by the human eye

Energy Savings PCA EXCEL

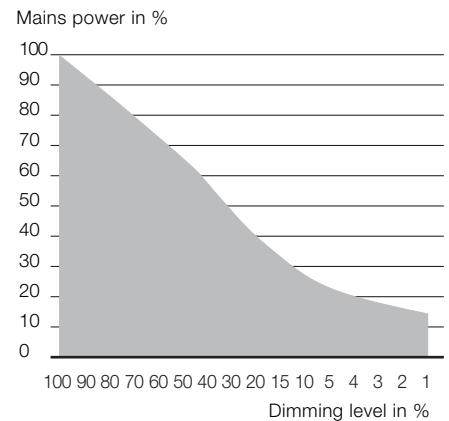

The installation of the two wire bus is according to the appropriate low voltage regulations.

switchDIM:

Integrated switchDIM function allows a direct connection of a push to make switch for dimming and switching.

Brief push (< 0.6 s) switches ballast ON and OFF. The ballasts switch-ON at light level set at switch-OFF.

When the push to make switch is held, PCA ballasts are dimmed. After repush the PCA is dimmed in the opposite direction.

The switchDIM fade time is set to 3 s from min. to max. in the factory settings. With a 20 s push to the push to make switch this fade time can be changed to 6 s. In this instance the switchDIM application will be synchronized to 50 % light level after 10 s and after 20 s the light level rises to 100 % with the new fade time.

In installations with PCAs with different dimming levels or opposite dimming directions (e.g. after a system extension), all PCAs can be synchronized to 50 % dimming level by a 10 s push.

Use of push to make switch with indicator lamp is not permitted.

Backwards compatibility:

With a simple key combination a PCA EXCEL one4all Ip can be reset as a normal PCA EXCEL

from the previous generation. Synchronisation simply has to take place three times within one minute (3x10 s). To activate the "Ip" settings again, synchronisation has to take place four times within one minute.

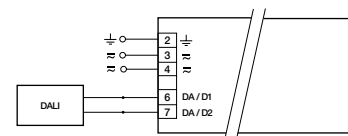

DALI PCA T5 EXCEL one4all Ip

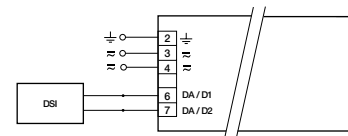

DSI PCA T5 EXCEL one4all Ip

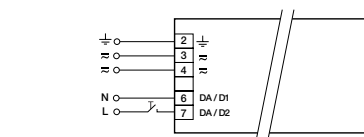

switchDIM PCA T5 EXCEL one4all Ip

Loading of automatic circuit breakers:

Automatic circuit	C10	C13	C16	C20	B10	B13	B16	B20
Installation Ø	1.5 mm ²	1.5 mm ²	1.5 mm ²	2.5 mm ²	1.5 mm ²	1.5 mm ²	1.5 mm ²	2.5 mm ²
PCA 1/24 T5 EXCEL Ip	50	80	150	180	25	40	75	90
PCA 1/39 T5 EXCEL Ip	34	50	70	86	17	25	38	43
PCA 1/49 T5 EXCEL Ip	24	34	48	52	12	17	24	26
PCA 1/54 T5 EXCEL Ip	24	34	48	52	12	17	24	26
PCA 1/80 T5 EXCEL Ip	14	20	28	28	7	10	14	14
PCA 2/24 T5 EXCEL Ip	24	34	48	52	12	17	24	26
PCA 2/39 T5 EXCEL Ip	16	22	30	32	8	11	15	16
PCA 2/49 T5 EXCEL Ip	12	18	26	26	6	9	13	13
PCA 2/54 T5 EXCEL Ip	12	18	26	26	6	9	13	13
PCA 2/80 T5 EXCEL Ip	10	14	20	22	5	7	10	11

**Electronic ballasts for dimming to 1 %
Linear lamps T5, 16 mm high output**

Installation instructions:

Wiring type and cross section:

The wiring can be solid cable with a cross section of 0.5 to 0.75 mm² for push terminal and 0.5 mm² for concut terminal. For the push-wire connection you have to strip the insulation (8–9 mm).

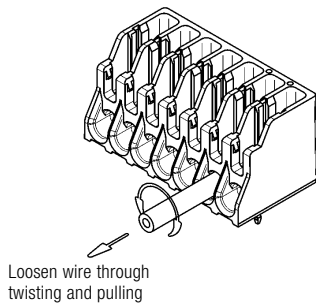
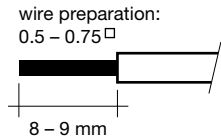

Ballast Typ	U _{out}
PCA 1/24 T5 EXCEL Ip	220–240V 50/60/0Hz 300 V
PCA 1/39 T5 EXCEL Ip	220–240V 50/60/0Hz 400 V
PCA 1/49 T5 EXCEL Ip	220–240V 50/60/0Hz 460 V
PCA 1/54 T5 EXCEL Ip	220–240V 50/60/0Hz 460 V
PCA 1/80 T5 EXCEL Ip	220–240V 50/60/0Hz 460 V
PCA 2/24 T5 EXCEL Ip	220–240V 50/60/0Hz 430 V
PCA 2/39 T5 EXCEL Ip	220–240V 50/60/0Hz 460 V
PCA 2/49 T5 EXCEL Ip	220–240V 50/60/0Hz 460 V
PCA 2/54 T5 EXCEL Ip	220–240V 50/60/0Hz 460 V
PCA 2/80 T5 EXCEL Ip	220–240V 50/60/0Hz 430 V

RFI:

- Connection to the lamps of the hot leads must be kept as short as possible
- Mains leads should be kept apart from lamp leads (ideally 5–10 cm distance)
- Do not run mains leads adjacent to the electronic ballast
- Twist the lamp leads
- Keep the distance of lamp leads from the metal work as large as possible
- Mains wiring to be twisted when through wiring
- Keep the mains leads inside the luminaire as short as possible

General advise:

Electronic ballasts are virtually noise free. Magnetic fields generated during the ignition cycle can cause some background noise but only for a few milliseconds.

① For further technical information please visit www.tridonicatco.com

Wiring advice:

The lead length is dependent on the capacitance of the cable.

Ballast Type	Terminal		Maximum capacitance allowed	
	Cold	Hot	Cold	Hot
PCA 1/xx T5 EXCEL Ip	11, 12	9, 10	200 pF	100 pF
PCA 2/xx T5 EXCEL Ip	11, 12, 13, 14	9, 10, 15, 16	200 pF	100 pF

With standard solid wire 0.5/0.75 mm² the capacitance of the lead is 30–80 pF/m.

This value is influenced by the way the wiring is made.

Lamp connection should be made with symmetrical wiring.

Hot leads (9, 10, 15, 16) and cold leads (11, 12, 13, 14) should be separated as much as possible.

When using two or more dimmable ballasts in one luminaire with separate dimming controls, the lamp leads must be kept separate.

Dimmable ballasts from TridonicAtco have to be earthed.

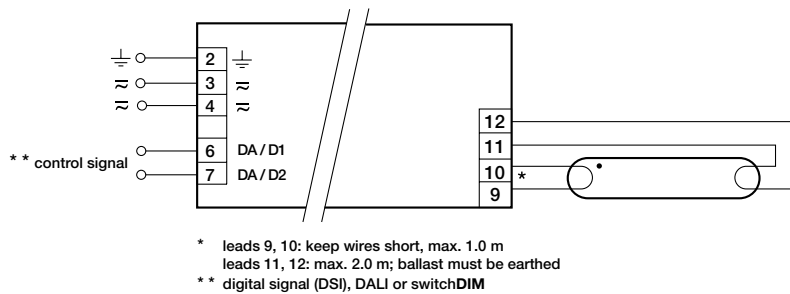

PCA T5 EXCEL one4all Ip 24–80 W

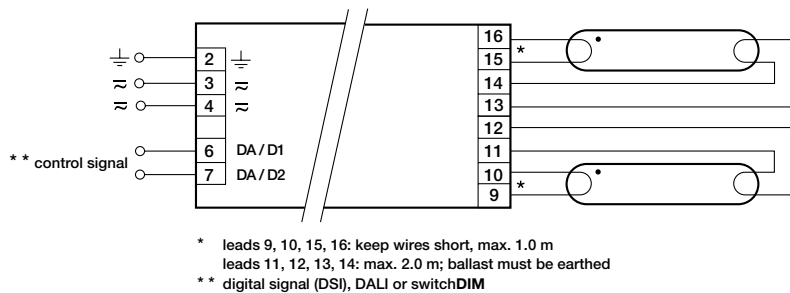

PCA T5 EXCEL one4all Ip 2x24–2x80 W

Programming:

With appropriate software and a USB interface different functions can be activated and various parameters can be configured in the new PCA EXCEL one4all Ip. All that is needed is a DALI-USB and the software.

configTOOL

Full version for programming all the functions and parameters.

pcaCONFIGURATOR

For programming the corridorFUNCTION, device configuration (fade time, ePowerOnLevel, etc.) DC level, compatibility settings, and startup date and for resetting.

corridorFUNCTION CONFIGURATOR

For activating and deactivating the corridor-FUNCTION and for project-specific programming of the PCA EXCEL one4all units.

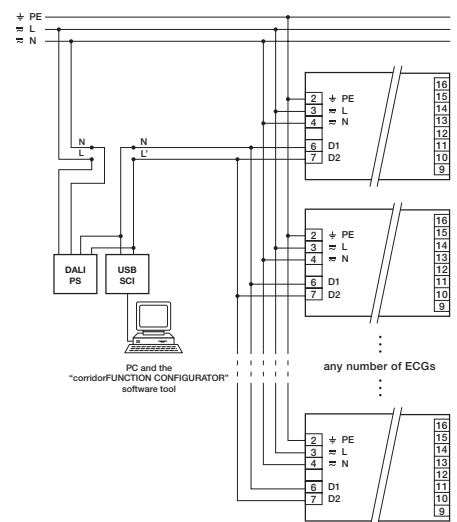

Wiring diagram for programming