

Electronic ballasts for dimming to 1 % Linear lamps

PCA EXCEL one4all 18–58 W 220–240 V 50/60/0 Hz, dimmable

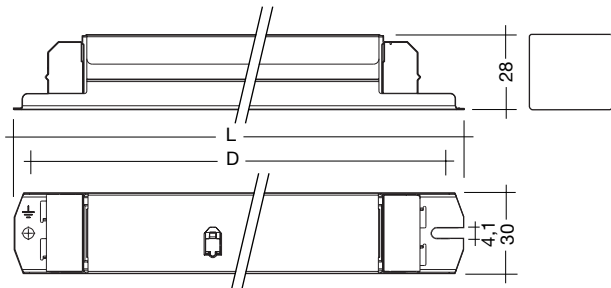

- dimming range from 1–100 %
- lamp start at 1 % possible
- lamp friendly warm start within 0.6 s with AC and DC
- switch via the mains or with digital control signal
- dimming which is comfortable to the eye
- disturbance free precise control with a digital signal (**DSI**), **switchDIM** or **DALI** (digital addressable lighting interface)
- error feed back and programmable features in both DALI and DSI mode
- integrated SMART interface
- fully electronic lamp management and digital communication with ASIC and μC
- constant light output independent of fluctuating supply voltage
- DC operation in emergency lighting installations to VDE 0108
- safe shutdown of defective lamps
- safe shutdown of lamps at end of life (rectifying effect)
- automatic restart after lamp replacement
- operating frequency ~40–100 kHz
- **NEW:** with DALI-MEMORY and corridor**FUNCTION**

Packaging:
box of 10
58 boxes/pallet
580 pieces/pallet

Certified:
EN 55015
EN 55022
EN 60929
EN 61000-3-2
EN 61347-2-3
EN 61547
in accordance
with VDE 0108

| Lamp | | Ballast | | | | | | | | | | |
|-------------------|--------|-----------------------------------|-------------------|-------------------|---------------------------|--------------|-------------------------|----------------------|--------------------------------|---------------------------|----------------|------------------------------|
| watt- age W | length | type | article number | length L mm | fixing centres D mm | weight kg | circuit power W ② | lamp power W ② | current at 230V/50Hz A ② | λ at 230V/50Hz | tc point °C | temperature range ① °C |
| 18 | 590 | PCA 1/18 EXCEL 220–240V 50/60/0Hz | 22085245 | 360 | 350 | 0.32 | 20.8 | 16 | 0.1 | 0.93 | 65 | -25 → +60 |
| 2x18 | 590 | PCA 2/18 EXCEL 220–240V 50/60/0Hz | 22085251 | 360 | 350 | 0.36 | 39.6 | 2x16 | 0.18 | 0.96 | 75 | -25 → +60 |
| 30 | 900 | PCA 1/30 EXCEL 220–240V 50/60/0Hz | 22086092 | 360 | 350 | 0.32 | 30.1 | 25 | 0.135 | 0.96 | 80 | -25 → +60 |
| 2x30 | 900 | PCA 2/30 EXCEL 220–240V 50/60/0Hz | 22086107 | 360 | 350 | 0.36 | 58 | 2x25 | 0.26 | 0.98 | 75 | -25 → +60 |
| 36 | 1200 | PCA 1/36 EXCEL 220–240V 50/60/0Hz | 22085264 | 360 | 350 | 0.32 | 36.5 | 32 | 0.165 | 0.97 | 70 | -25 → +60 |
| 2x36 | 1200 | PCA 2/36 EXCEL 220–240V 50/60/0Hz | 22085270 | 360 | 350 | 0.36 | 70.4 | 2x32 | 0.305 | 0.98 | 80 | -25 → +60 |
| 38 | 1200 | PCA 1/38 EXCEL 220–240V 50/60/0Hz | 22087027 | 360 | 350 | 0.32 | 37.3 | 32 | 0.170 | 0.98 | 70 | -25 → +60 |
| 2x38 | 1200 | PCA 2/38 EXCEL 220–240V 50/60/0Hz | 22087033 | 360 | 350 | 0.36 | 71.1 | 2x32 | 0.315 | 0.99 | 75 | -25 → +60 |
| 58 | 1500 | PCA 1/58 EXCEL 220–240V 50/60/0Hz | 22085286 | 360 | 350 | 0.32 | 56 | 50 | 0.25 | 0.98 | 75 | -25 → +60 |
| 2x58 | 1500 | PCA 2/58 EXCEL 220–240V 50/60/0Hz | 22084608 | 360 | 350 | 0.36 | 111 | 100 | 0.49 | 0.98 | 75 | -25 → +50 |

① dimming to 1 % between 0 °C to t_a max.

② valid at 100 % light output

Electronic ballasts for dimming to 1 %
Linear lamps

Lamp starting characteristics:

Warm start
 Starting time 0.6 s with AC
 Starting time 0.6 s with DC
 Start at any dimming level

AC operation:

Mains voltage
 220–240 V 50/60 Hz
 198–264 V 50/60 Hz including safety
 tolerance ($\pm 10\%$)
 202–254 V 50/60 Hz including performance
 tolerance (+6% / -8%)

DC operation:

220–240 V 0 Hz
 198–280 V 0 Hz certain lamp start
 176–280 V 0 Hz operating range
 Use in emergency lighting installations
 according to VDE 0108 or for emergency
 luminaires according to EN 61347-2-3 appendix J.

Temperature range:

Dimming range 100 % to 1 % from 0 °C to
 maximum permissible ambient temperature t_a .
 100 % operation from -25 °C to maximum
 permissible ambient temperature t_a .

Mains currents in DC operation:

| Ballast Type | Mains current at $U_n = 220$ VDC | Mains current at $U_n = 240$ VDC |
|-----------------------------------|-------------------------------------|-------------------------------------|
| PCA 1/18 EXCEL 220–240V 50/60/0Hz | 0.08 A | 0.07 A |
| PCA 1/30 EXCEL 220–240V 50/60/0Hz | 0.11 A | 0.10 A |
| PCA 1/36 EXCEL 220–240V 50/60/0Hz | 0.14 A | 0.13 A |
| PCA 1/38 EXCEL 220–240V 50/60/0Hz | 0.14 A | 0.13 A |
| PCA 1/58 EXCEL 220–240V 50/60/0Hz | 0.22 A | 0.20 A |
| PCA 2/18 EXCEL 220–240V 50/60/0Hz | 0.14 A | 0.13 A |
| PCA 2/30 EXCEL 220–240V 50/60/0Hz | 0.21 A | 0.19 A |
| PCA 2/36 EXCEL 220–240V 50/60/0Hz | 0.25 A | 0.23 A |
| PCA 2/38 EXCEL 220–240V 50/60/0Hz | 0.26 A | 0.23 A |
| PCA 2/58 EXCEL 220–240V 50/60/0Hz | 0.42 A | 0.38 A |

Light output level in DC operation:

Programmable from 1 % to 70 %
 Programming by extended DSI signal (16 bit)
 Default value is 70 %
 In DC operation dimming is not possible

Ballast lumen factor AC operation (AC-BLF) EN 60929 8.1:

| Ballast Type | AC-BLF at $U_n = 230$ VAC |
|-----------------------------------|------------------------------|
| PCA 1/18 EXCEL 220–240V 50/60/0Hz | 1.01 |
| PCA 1/30 EXCEL 220–240V 50/60/0Hz | 1.00 |
| PCA 1/36 EXCEL 220–240V 50/60/0Hz | 0.99 |
| PCA 1/38 EXCEL 220–240V 50/60/0Hz | 1.07 |
| PCA 1/58 EXCEL 220–240V 50/60/0Hz | 1.00 |
| PCA 2/18 EXCEL 220–240V 50/60/0Hz | 1.00 |
| PCA 2/30 EXCEL 220–240V 50/60/0Hz | 0.99 |
| PCA 2/36 EXCEL 220–240V 50/60/0Hz | 1.00 |
| PCA 2/38 EXCEL 220–240V 50/60/0Hz | 1.00 |
| PCA 2/58 EXCEL 220–240V 50/60/0Hz | 0.99 |

The ballast lumen factor for AC operation (AC-BLF) does not alter from $U_n = 198$ VAC to $U_n = 254$ VAC.

The ballast lumen factor for DC operation (DC-BLF) on the basis of an automatic power reduction of the ballasts (default value is 70 %) will be smaller than AC. It does not alter in the DC operating range (198–280 VDC).

Harmonic distortion in the mains supply (at 220 V/50 Hz):

| Ballast Type | THD | 3 | 5 | 7 | 9 | 11 |
|-----------------------------------|------|------|-----|-----|-----|-----|
| PCA 1/18 EXCEL 220–240V 50/60/0Hz | 13.9 | 13.2 | 3.7 | 2.2 | 1.4 | 1.1 |
| PCA 1/30 EXCEL 220–240V 50/60/0Hz | 11.7 | 10.2 | 3.6 | 2.2 | 1.5 | 1.1 |
| PCA 1/36 EXCEL 220–240V 50/60/0Hz | 8.7 | 8.3 | 2.2 | 1.4 | 1.0 | 0.7 |
| PCA 1/38 EXCEL 220–240V 50/60/0Hz | 9.3 | 8.6 | 2.9 | 1.8 | 1.2 | 0.9 |
| PCA 1/58 EXCEL 220–240V 50/60/0Hz | 8.3 | 7.5 | 3.0 | 1.8 | 1.2 | 0.8 |
| PCA 2/18 EXCEL 220–240V 50/60/0Hz | 8.4 | 7.9 | 2.2 | 1.9 | 1.7 | 1.6 |
| PCA 2/30 EXCEL 220–240V 50/60/0Hz | 8.9 | 8.3 | 2.7 | 1.8 | 1.3 | 1.1 |
| PCA 2/36 EXCEL 220–240V 50/60/0Hz | 6.2 | 5.8 | 1.9 | 1.2 | 0.9 | 0.7 |
| PCA 2/38 EXCEL 220–240V 50/60/0Hz | 7.5 | 6.8 | 2.5 | 1.7 | 1.3 | 1.0 |
| PCA 2/58 EXCEL 220–240V 50/60/0Hz | 6.6 | 5.9 | 2.4 | 1.6 | 1.2 | 0.8 |

Dimming:

Dimming range 1 % to 100 %

Digital control with:

- DSI signal: 8 bit Manchester Code
Maximum speed 1 % to 100 % in 1.4 s
 - DALI signal: 16 bit Manchester Code
Maximum speed 1 % to 100 % in 0.5 s
- Programmable parameter:
Minimum dimming level
Maximum dimming level
Default minimum = 1 %
Programmable range $1\% \leq \text{MIN} \leq 49\%$
Default maximum = 100 %
Programmable range $100\% \geq \text{MAX} \geq 50\%$

Dimming curve that is friendly to the eye.

Dimming characteristics PCA EXCEL

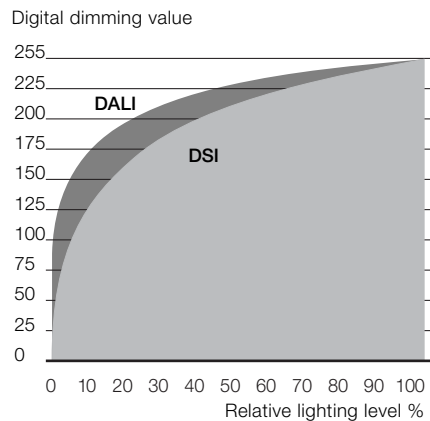

Dimming characteristics as seen by the human eye

Energy Savings PCA EXCEL

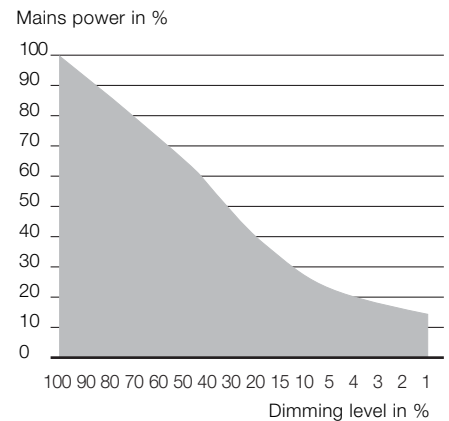

Control input (D1, D2):

Digital DALI/DSI signal or switchDIM can be wired on the same terminals (D1 and D2).

Digital signal DALI/DSI:

The control input is non-polar and protected against accidental connection with a mains voltage up to 264V. The control signal is not SELV. Control cable should be installed in accordance to the requirements of low voltage installations.

Different functions depending on each module.

SMART interface:

An additional interface for the direct connection of the SMART-LS light sensor. The sensor registers actual ambient light and maintains the individually defined lux level.

After every mains reset the SMART interface automatically checks for an installed sensor. With the sensor installed the PCA EXCEL automatically runs in the constant lux level mode.

ON/OFF-Switch via mains, switchDIM or DALI/DSI signal.

DALI/DSI signal = 0 switches off,
DALI/DSI signal ≥ 1 switches on.

Dimming with DALI or a DSI signal with the SMART-LS installed is not possible.

switchDIM enables a temporary change of light level.

The installation of the two wire bus is according to the appropriate low voltage regulations.

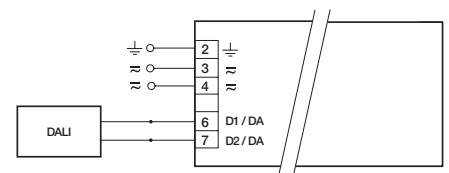

DALI PCA EXCEL one4all

switchDIM:

Integrated switchDIM function allows a direct connection of a push to make switch for dimming and switching.

Brief push (< 0.6 s) switches ballast ON and OFF. The ballasts switch-ON at light level set at switch-OFF.

When the push to make switch is held, PCA ballasts are dimmed. After repush the PCA is dimmed in the opposite direction.

In installations with PCAs with different dimming levels or opposite dimming directions (e.g. after a system extension), all PCAs can be synchronized to 50 % dimming level by a 10 s push.

Use of push to make switch with indicator lamp is not permitted.

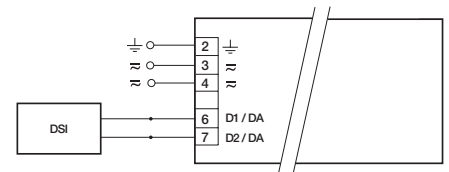

DSI PCA EXCEL one4all

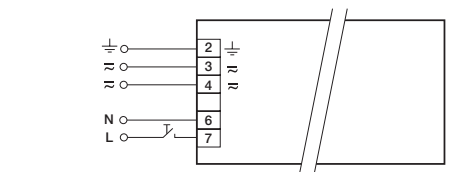

switchDIM PCA EXCEL one4all

Loading of automatic circuit breakers:

Automatic circuit

| breaker type | C10 | C13 | C16 | C20 | B10 | B13 | B16 | B20 |
|----------------------------|---------------------|---------------------|---------------------|---------------------|---------------------|---------------------|---------------------|---------------------|
| Installation \varnothing | 1.5 mm ² | 1.5 mm ² | 1.5 mm ² | 2.5 mm ² | 1.5 mm ² | 1.5 mm ² | 1.5 mm ² | 2.5 mm ² |
| PCA 1/18 EXCEL | 30 | 50 | 76 | 80 | 15 | 25 | 38 | 40 |
| PCA 1/30 EXCEL | 30 | 50 | 70 | 76 | 15 | 25 | 35 | 38 |
| PCA 1/36 EXCEL | 30 | 50 | 70 | 76 | 15 | 25 | 35 | 38 |
| PCA 1/38 EXCEL | 30 | 50 | 70 | 76 | 15 | 25 | 35 | 38 |
| PCA 1/58 EXCEL | 20 | 30 | 40 | 46 | 10 | 15 | 20 | 23 |
| PCA 2/18 EXCEL | 20 | 30 | 40 | 46 | 10 | 15 | 20 | 23 |
| PCA 2/30 EXCEL | 10 | 20 | 30 | 30 | 5 | 10 | 15 | 15 |
| PCA 2/36 EXCEL | 10 | 20 | 30 | 30 | 5 | 10 | 15 | 15 |
| PCA 2/38 EXCEL | 10 | 20 | 30 | 30 | 5 | 10 | 15 | 15 |
| PCA 2/58 EXCEL | 10 | 20 | 30 | 30 | 5 | 10 | 15 | 15 |

**Electronic ballasts for dimming to 1 %
Linear lamps**

Installation instructions:

Wiring type and cross section:

The wiring can be solid cable with a cross section of 0.5 to 1.5 mm² for push terminal and 0.5 mm² for concut terminal. For the push-wire connection you have to strip the insulation (7.5–8.5 mm).

$U_{out} = 250\text{ V } 250$

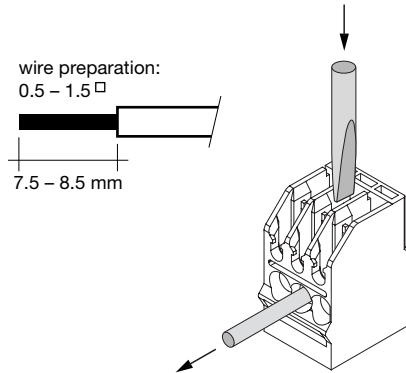

Wiring advice:

The lead length is dependent on the capacitance of the cable.

| Ballast Type | Terminal | | Maximum capacitance allowed | |
|----------------|----------------|---------------|-----------------------------|--------|
| | Cold | Hot | Cold | Hot |
| PCA 1/xx EXCEL | 11, 12 | 9, 10 | 200 pF | 100 pF |
| PCA 2/xx EXCEL | 11, 12, 13, 14 | 9, 10, 15, 16 | 200 pF | 100 pF |

With standard solid wire 0.5/0.75 mm² the capacitance of the lead is 30–80 pF/m. This value is influenced by the way the wiring is made.

Lamp connection should be made with symmetrical wiring. Hot leads (9, 10, 15, 16) and cold leads (11, 12, 13, 14) should be separated as much as possible.

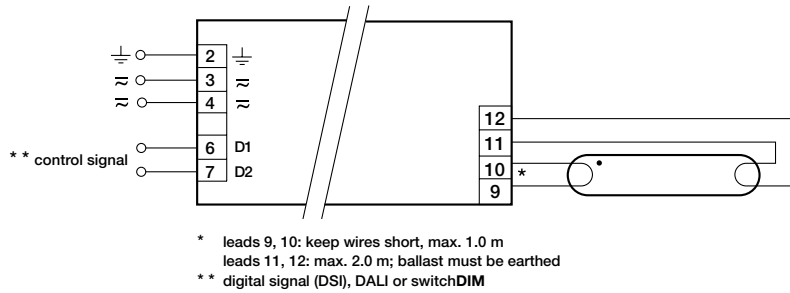

RFI:

- Connection to the lamps of the hot leads must be kept as short as possible
- Mains leads should be kept apart from lamp leads (ideally 5–10 cm distance)
- Do not run mains leads adjacent to the electronic ballast
- Twist the lamp leads
- Keep the distance of lamp leads from the metal work as large as possible
- Ballast must be earthed
- Mains wiring to be twisted when through wiring
- Keep the mains leads inside the luminaire as short as possible

PCA EXCEL one4all 18–58 W

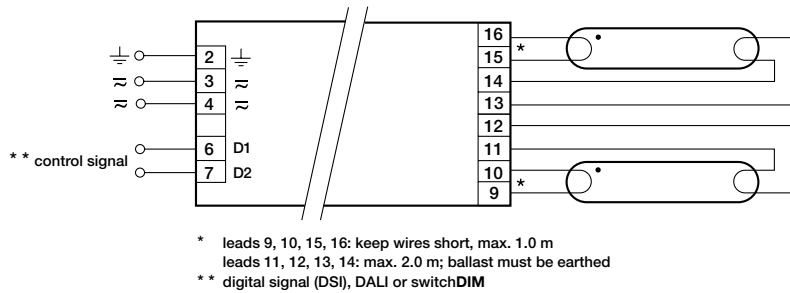

Important advise:

- When using two or more dimmable ballasts in one luminaire with separate dimming controls, the lamp leads must be kept separate
- All lamps must have the same length lead

PCA EXCEL one4all 2x18–2x58 W